

## Features

- P-Channel
- Fast Switching
- High Power and current handing capability
- Lead free product is acquired
- 100% EAS Tested

$V_{DS}$	-100	V
$R_{DS(on),TYP@ V_{GS}=-10V}$	85	m $\Omega$
$R_{DS(on),TYP@ V_{GS}=-4.5V}$	89	m $\Omega$
$I_D$	-19	A

### TO-252

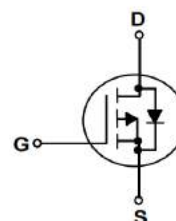

Part ID	Package Type	Marking	Packing
ZT85P10D	TO-252	ZT85P10D	2500pcs/reel

### Absolute Maximum Ratings $T_A = 25^\circ\text{C}$ , unless otherwise specified

Symbol	Parameter	Rating	Unit	
<b>Common Ratings (<math>T_C=25^\circ\text{C}</math> Unless Otherwise Noted)</b>				
$V_{GS}$	Gate-Source Voltage	$\pm 20$	V	
$V_{(BR)DSS}$	Drain-Source Breakdown Voltage	-100	V	
$T_J$	Maximum Junction Temperature	175	$^\circ\text{C}$	
$T_{STG}$	Storage Temperature Range	-55 to 175	$^\circ\text{C}$	
$I_{DM}$	Drain Current-Continuous@ Current-Pulsed (Note 1)	$T_C = 25^\circ\text{C}$ -76	A	
<b>Mounted on Large Heat Sink</b>				
$I_D$	Drain Current-Continuous	$T_C = 25^\circ\text{C}$	-19	A
		$T_C = 100^\circ\text{C}$	-13.5	A
$P_D$	Maximum Power Dissipation	$T_C = 25^\circ\text{C}$	79	W
		$T_C = 100^\circ\text{C}$	39.5	W
$R_{\theta JC}$	Thermal Resistance-Junction to Case	1.9	$^\circ\text{C/W}$	
<b>Drain-Source Avalanche Ratings</b>				
EAS	Avalanche Energy, Single Pulsed (Note 2)	156	mJ	

**Electrical Characteristics (T<sub>J</sub>=25°C unless otherwise noted)**

Symbol	Parameter	Condition	Min	Typ	Max	Unit
<b>Static Electrical Characteristics @ T<sub>J</sub>=25°C (unless otherwise stated)</b>						
V(BR)DSS	Drain-Source Breakdown Voltage	V <sub>GS</sub> =0V, I <sub>D</sub> =-250μA	-100	-121	--	V
I <sub>DSS</sub>	Zero Gate Voltage Drain Current	V <sub>DS</sub> =-100V, V <sub>GS</sub> =0V	--	--	-1	μA
I <sub>GSS</sub>	Gate-Body Leakage Current	V <sub>GS</sub> =±20V, V <sub>DS</sub> =0V	--	--	±100	nA
V <sub>GS(th)</sub>	Gate Threshold Voltage	V <sub>DS</sub> =V <sub>GS</sub> , I <sub>D</sub> =-250μA	-1.0	-1.7	-2.5	V
R <sub>DS(on)</sub>	Drain-Source On-State Resistance	V <sub>GS</sub> =-10V, I <sub>D</sub> =-10A	--	85	102	mΩ
R <sub>DS(on)</sub>	Drain-Source On-State Resistance	V <sub>GS</sub> =-4.5V, I <sub>D</sub> =-8A	--	89	115	mΩ
g <sub>FS</sub>	Forward Transconductance	V <sub>DS</sub> =-5V, I <sub>D</sub> =-10A	--	26	--	S
<b>Dynamic Electrical Characteristics @ T<sub>J</sub> = 25°C (unless otherwise stated)</b>						
C <sub>iss</sub>	Input Capacitance	V <sub>DS</sub> =-25V, V <sub>GS</sub> =0V, f=1MHz	--	3693	--	pF
C <sub>oss</sub>	Output Capacitance		--	90	--	pF
C <sub>rss</sub>	Reverse Transfer Capacitance		--	32	--	pF
Q <sub>g</sub>	Total Gate Charge	V <sub>DS</sub> =-50V, I <sub>D</sub> =-10A, V <sub>GS</sub> =-10V	--	73	--	nC
Q <sub>gs</sub>	Gate-Source Charge		--	8.4	--	nC
Q <sub>gd</sub>	Gate-Drain Charge		--	17.3	--	nC
<b>Switching Characteristics</b>						
T <sub>d(on)</sub>	Turn-on Delay Time	V <sub>DS</sub> =-50V, R <sub>L</sub> =5Ω, R <sub>G</sub> =9.1Ω, V <sub>GS</sub> =-10V	--	6	--	ns
T <sub>r</sub>	Turn-on Rise Time		--	29	--	ns
T <sub>d(off)</sub>	Turn-Off Delay Time		--	17	--	ns
T <sub>f</sub>	Turn-Off Fall Time		--	24	--	ns
<b>Source- Drain Diode Characteristics @ T<sub>J</sub> = 25°C (unless otherwise stated)</b>						
I <sub>SD</sub>	Source-Drain Current (Body Diode)		--	--	-19	A
V <sub>SD</sub>	Forward on voltage (Note 3)	I <sub>S</sub> =-10A, V <sub>GS</sub> =0V	--	--	-1.2	V
T <sub>rr</sub>	Reverse Recovery Time	T <sub>J</sub> =25°C, I <sub>F</sub> =-15A, V <sub>GS</sub> =0V di/dt=100A/μs	--	32	--	ns
Q <sub>rr</sub>	Reverse Recovery Charge		--	53	--	nC

**Notes :**

- 1.Repetitive Rating: Pulse width limited by maximum junction temperature.
- 2.E<sub>AS</sub> condition: T<sub>J</sub>=25°C, V<sub>DD</sub>=50V, V<sub>G</sub>=-10V, R<sub>G</sub>=25Ω, L=0.5mH.
- 3.Repetitive Rating: Pulse width limited by maximum junction temperature.

## Typical Electrical And Thermal Characteristics (Curves)

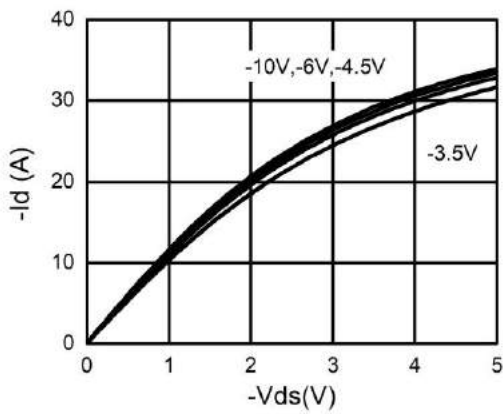

Figure 1. Output Characteristics

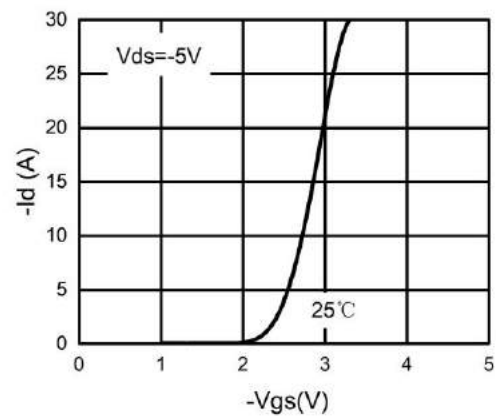

Figure 4. Transfer Characteristics

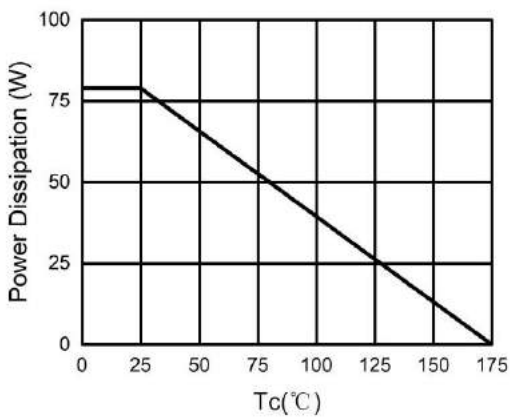

Figure 2. Power Dissipation

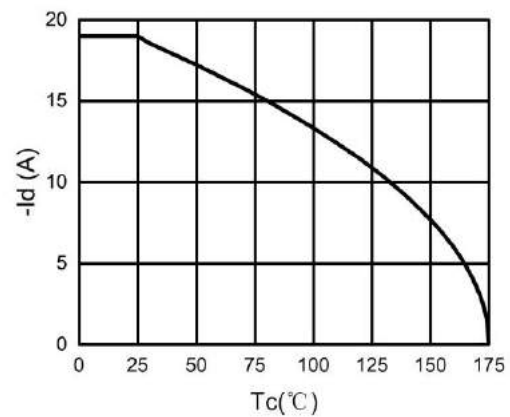

Figure 5. Drain Current

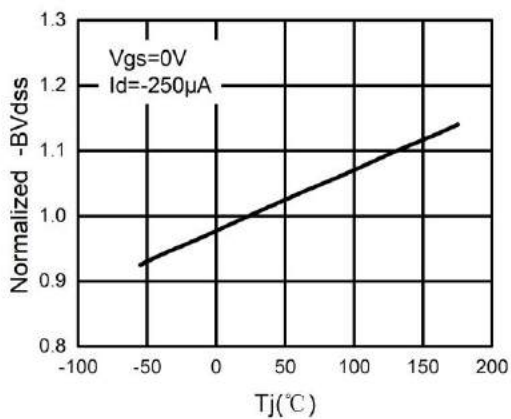

Figure 3.  $BV_{DSS}$  vs Junction Temperature

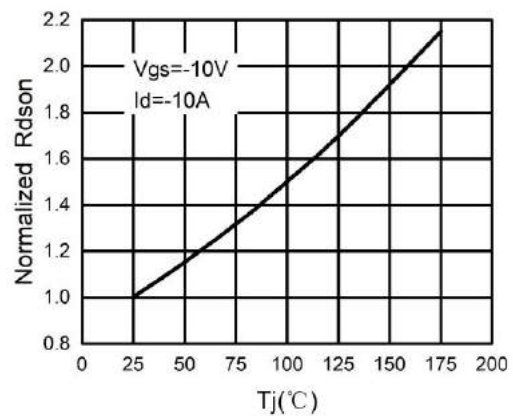

Figure 6.  $R_{DS(on)}$  vs Junction Temperature

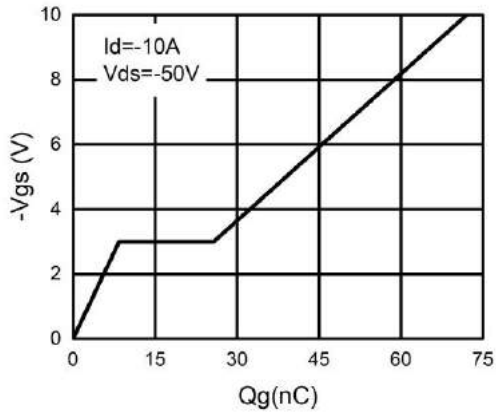

Figure 7. Gate Charge Waveforms

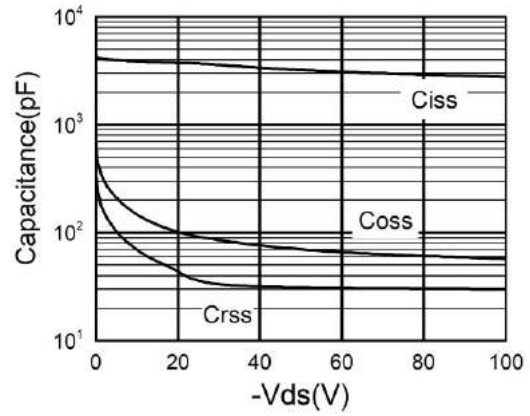

Figure 9. Capacitance

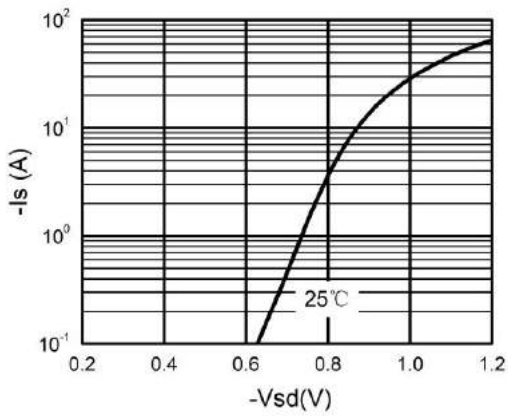

Figure 8. Body-Diode Characteristics

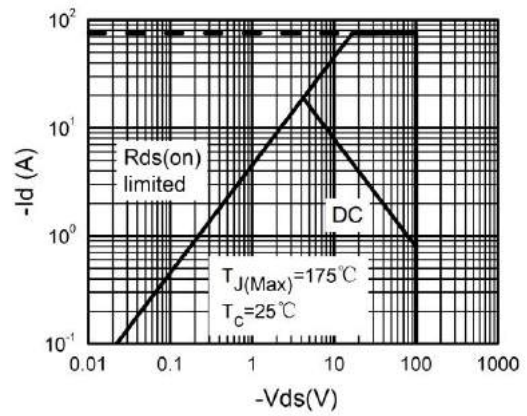
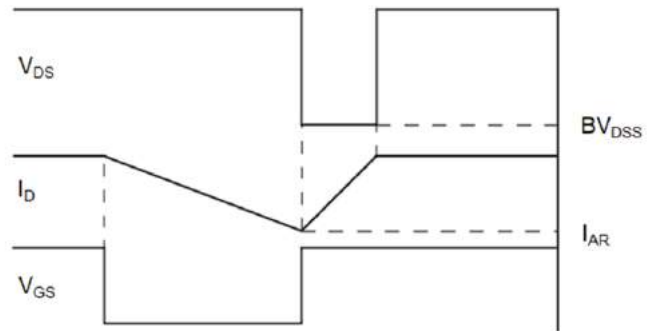
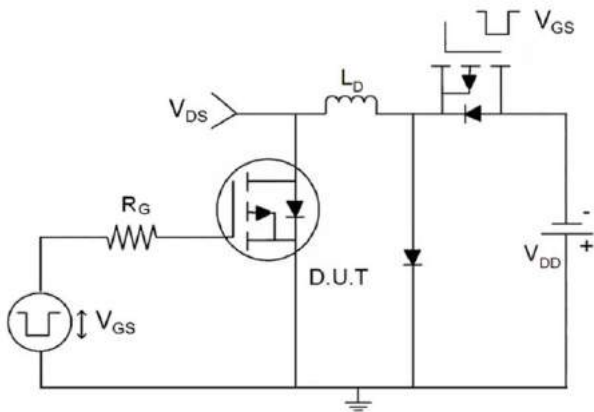

Figure 10. Maximum Safe Operating Area

## Test Circuit

### 1) $E_{AS}$ Test Circuits



### 2) Gate Charge Test Circuit

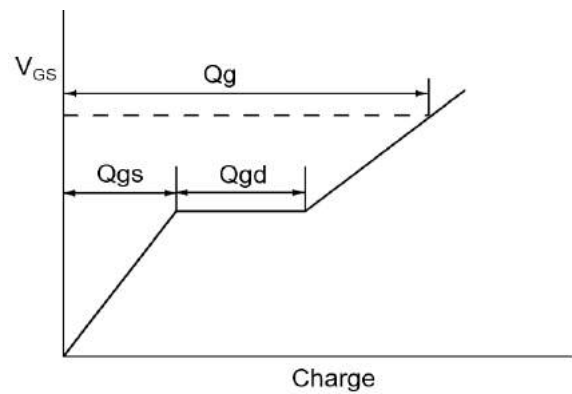
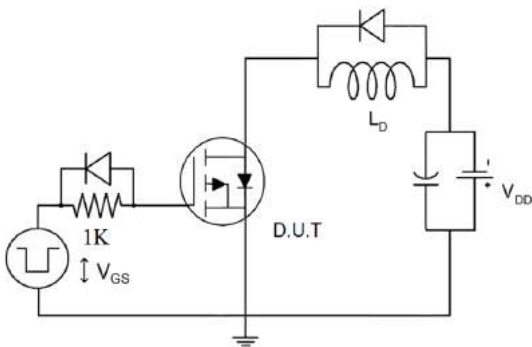

### 3) Switch Time Test Circuit

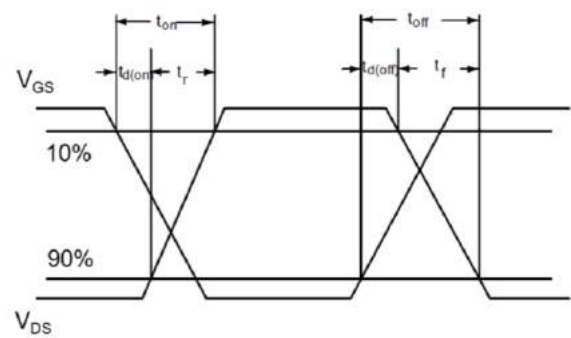
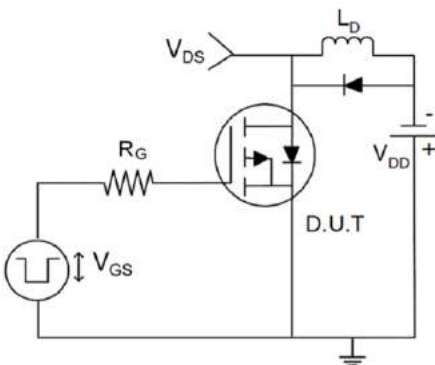

## TO-252 Package Information

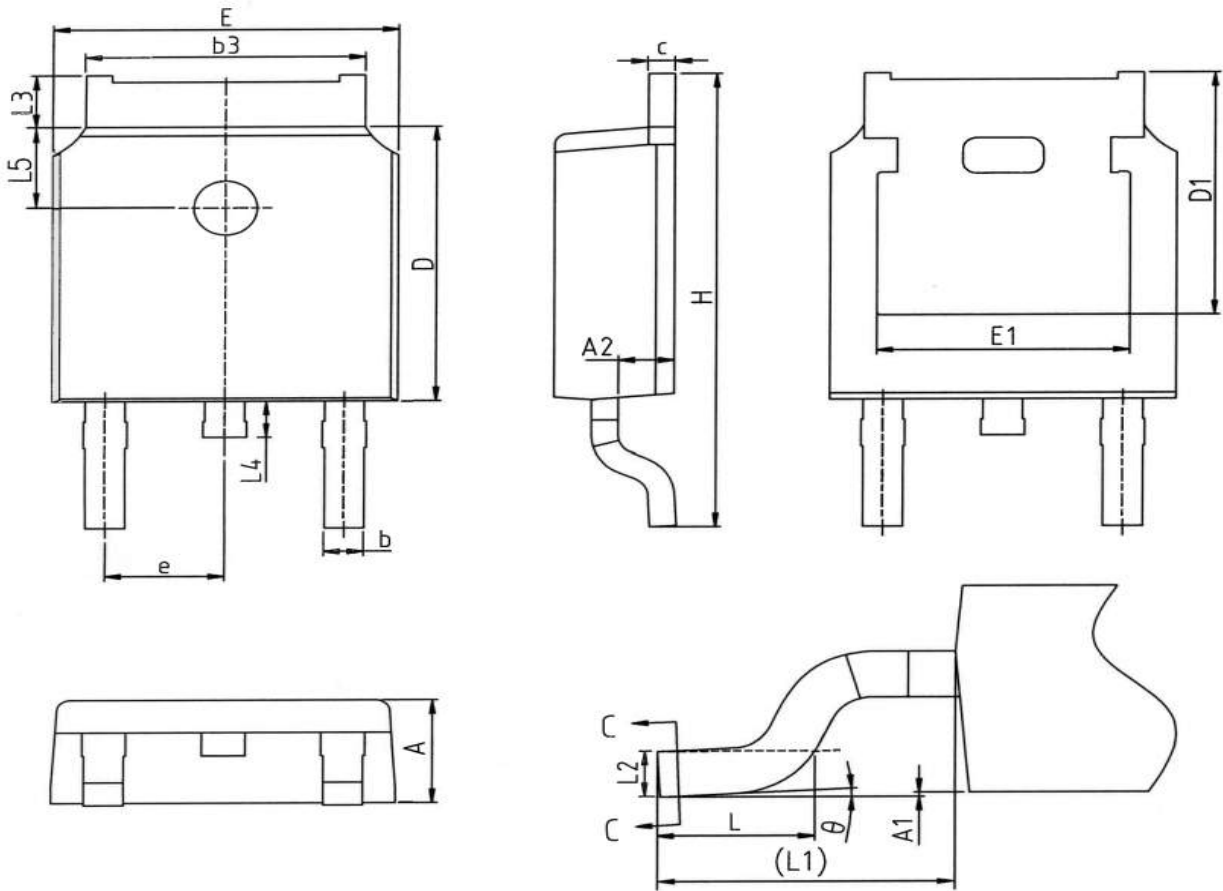

SYMBOL	mm		
	MIN	NOM	MAX
A	2.20	2.30	2.38
A1	0.00	-	0.12
A2	0.97	1.07	1.17
b	0.68	0.78	0.90
b3	5.20	5.33	5.46
c	0.43	0.53	0.61
D	5.98	6.10	6.22
D1	5.30REF		
E	6.40	6.60	6.73
E1	4.63	-	-
e	2.286BSC		
H	9.40	10.10	10.50
L	1.38	1.50	1.75
L1	2.90REF		
L2	0.51BSC		
L3	0.88	-	1.28
L4	0.50	-	1.00
L5	1.65	1.80	1.95
θ	0°	-	8°

## Customer Service

Sales and Service:

[zj@ztasemi.com](mailto:zj@ztasemi.com)