

Features

- P-Channel
- Fast Switching
- High Power and current handing capability
- Lead free product is acquired
- 100% EAS Tested

V_{DS}	-60	V
$R_{DS(on),TYP@ V_{GS}=-10V}$	24	m Ω
$R_{DS(on),TYP@ V_{GS}=-4.5V}$	30	m Ω
I_D	-50	A

TO-252

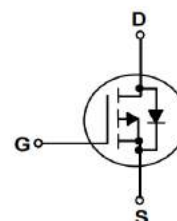

Part ID	Package Type	Marking	Packing
ZT24P06D	TO-252	ZT24P06D	2500pcs/reel

Absolute Maximum Ratings $T_A = 25^\circ\text{C}$, unless otherwise specified

Symbol	Parameter	Rating	Unit	
Common Ratings ($T_c=25^\circ\text{C}$ Unless Otherwise Noted)				
V_{GS}	Gate-Source Voltage	± 20	V	
$V_{(BR)DSS}$	Drain-Source Breakdown Voltage	-60	V	
T_J	Maximum Junction Temperature	175	$^\circ\text{C}$	
T_{STG}	Storage Temperature Range	-55 to 175	$^\circ\text{C}$	
I_{DM}	Drain Current-Continuous@ Current-Pulsed (Note 1)	$T_c = 25^\circ\text{C}$ -200	A	
Mounted on Large Heat Sink				
I_D	Drain Current-Continuous	$T_c = 25^\circ\text{C}$	-50	A
		$T_c = 100^\circ\text{C}$	-35.5	A
P_D	Maximum Power Dissipation	$T_c = 25^\circ\text{C}$	79	W
		$T_c = 100^\circ\text{C}$	39.5	W
$R_{\theta JC}$	Thermal Resistance-Junction to Case	1.9	$^\circ\text{C/W}$	
Drain-Source Avalanche Ratings				
EAS	Avalanche Energy, Single Pulsed (Note 2)	196	mJ	

Electrical Characteristics (T_J=25°C unless otherwise noted)

Symbol	Parameter	Condition	Min	Typ	Max	Unit
Static Electrical Characteristics @ T_J=25°C (unless otherwise stated)						
V(BR)DSS	Drain-Source Breakdown Voltage	V _{GS} =0V, I _D =-250μA	-60	--	--	V
I _{DSS}	Zero Gate Voltage Drain Current	V _{DS} =-60V, V _{GS} =0V	--	--	-1	μA
I _{GSS}	Gate-Body Leakage Current	V _{GS} =±20V, V _{DS} =0V	--	--	±100	nA
V _{GS(th)}	Gate Threshold Voltage	V _{DS} =V _{GS} , I _D =-250μA	-1.0	-1.8	-2.5	V
R _{DS(on)}	Drain-Source On-State Resistance	V _{GS} =-10V, I _D =-15A	--	24	29	mΩ
R _{DS(on)}	Drain-Source On-State Resistance	V _{GS} =-4.5V, I _D =-10A	--	30	38	mΩ
g _{FS}	Forward Transconductance	V _{DS} =-5V, I _D =-15A	--	35	--	S
Dynamic Electrical Characteristics @ T_J = 25°C (unless otherwise stated)						
C _{iss}	Input Capacitance	V _{DS} =-25V, V _{GS} =0V, f=1MHz	--	4026	--	pF
C _{oss}	Output Capacitance		--	134	--	pF
C _{rss}	Reverse Transfer Capacitance		--	98	--	pF
Q _g	Total Gate Charge	V _{DS} =-30V, I _D =-20A, V _{GS} =-10V	--	140	--	nC
Q _{gs}	Gate-Source Charge		--	19	--	nC
Q _{gd}	Gate-Drain Charge		--	28	--	nC
Switching Characteristics						
T _{d(on)}	Turn-on Delay Time	V _{DS} =-30V, R _L =1.5Ω, R _G =3Ω, V _{GS} =-10V	--	12.2	--	ns
T _r	Turn-on Rise Time		--	10	--	ns
T _{d(off)}	Turn-Off Delay Time		--	64	--	ns
T _f	Turn-Off Fall Time		--	14	--	ns
Source- Drain Diode Characteristics @ T_J = 25°C (unless otherwise stated)						
I _{SD}	Source-Drain Current (Body Diode)		--	--	-50	A
V _{SD}	Forward on voltage (Note 3)	I _S =-15A, V _{GS} =0V	--	--	-1.2	V
T _{rr}	Reverse Recovery Time	T _J =25°C, I _F =-20A, V _{GS} =0V	--	26	--	ns
Q _{rr}	Reverse Recovery Charge		di/dt=100A/μs	--	29	--

Notes:

- 1.Repetitive Rating: Pulse width limited by maximum junction temperature.
- 2.EAS condition: T_J=25°C, V_{DD}=40V, V_G=-10V, R_G=25Ω, L=0.5mH.
- 3.Repetitive Rating: Pulse width limited by maximum junction temperature.

Typical Electrical And Thermal Characteristics (Curves)

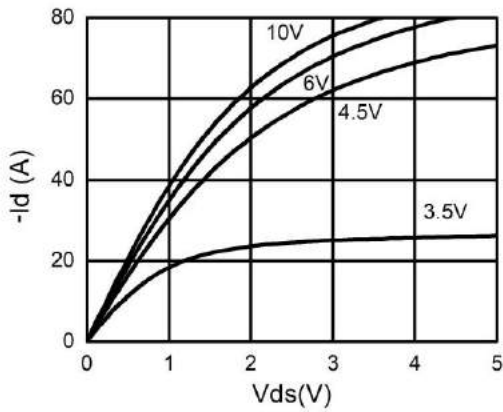

Figure 1. Output Characteristics

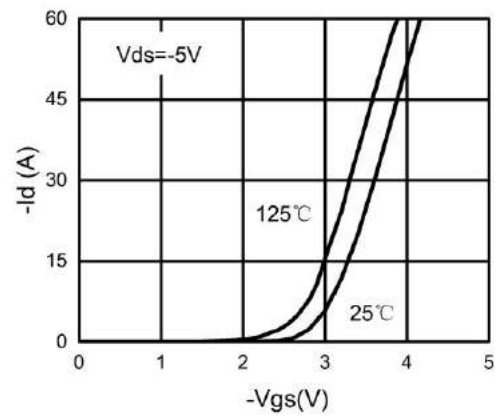

Figure 4. Transfer Characteristics

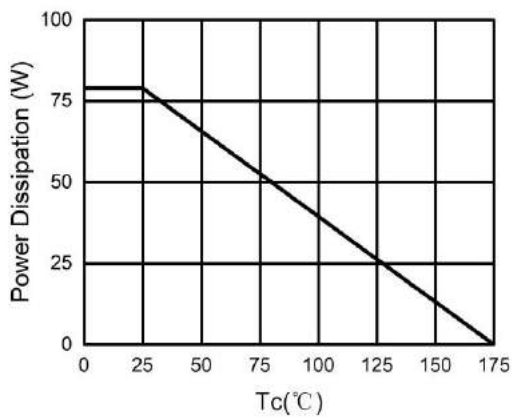

Figure 2. Power Dissipation

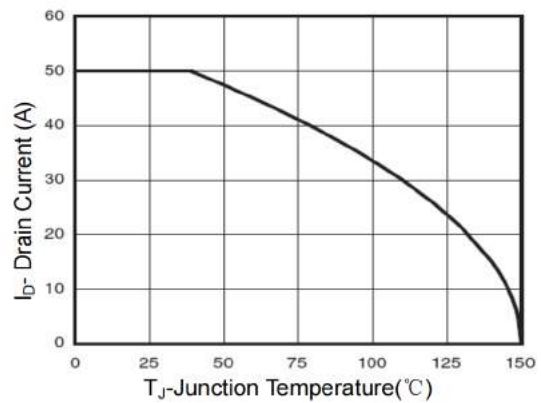

Figure 5. Drain Current

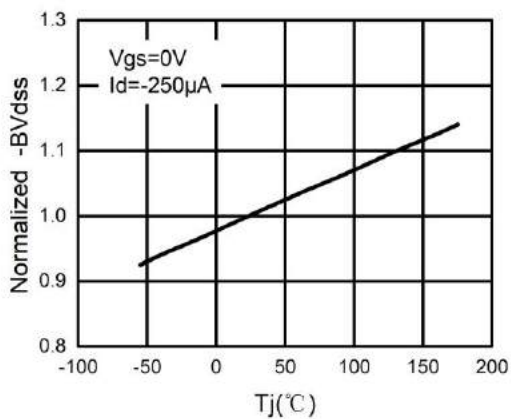

Figure 3. BV_{DSS} vs Junction Temperature

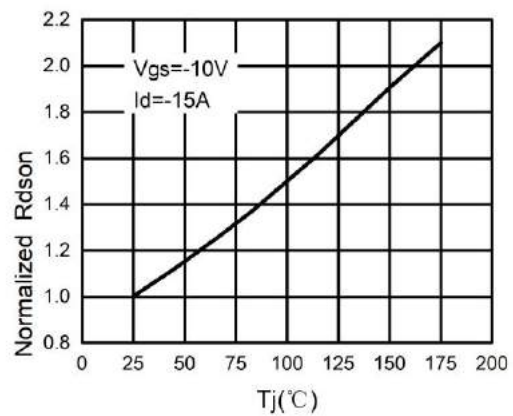

Figure 6. $R_{DS(ON)}$ vs Junction Temperature

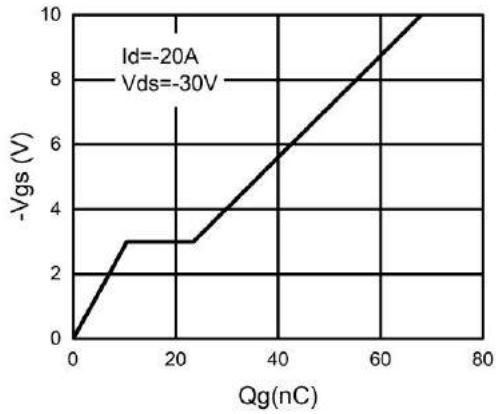

Figure 7. Gate Charge Waveforms

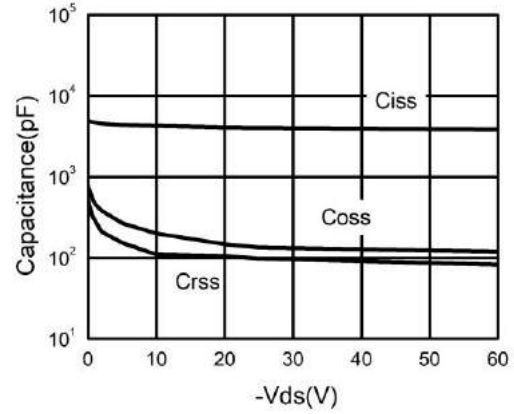

Figure 9. Capacitance

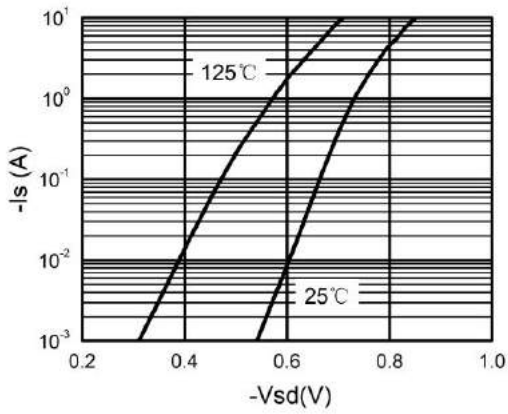

Figure 8. Body-Diode Characteristics

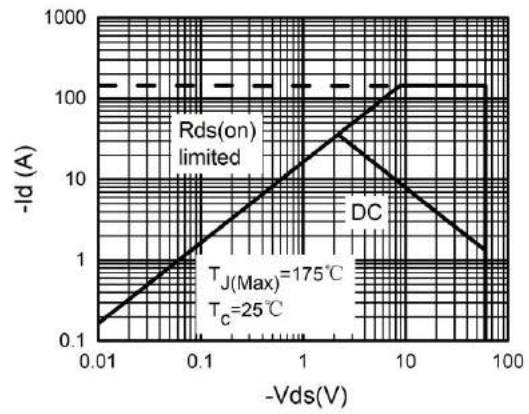
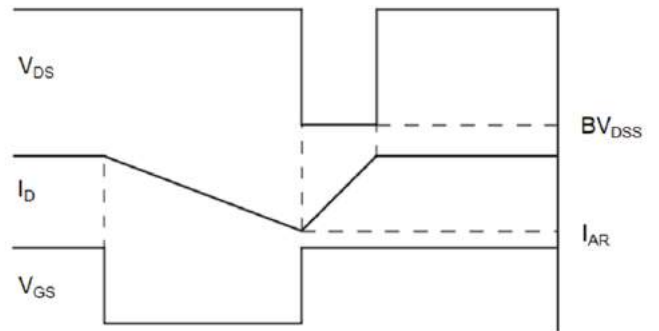
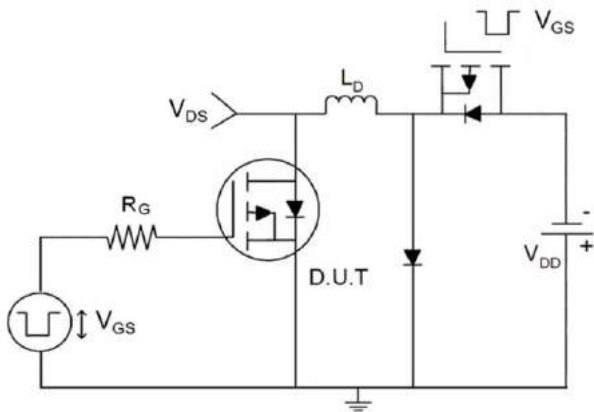

Figure 10. Maximum Safe Operating Area

Test Circuit

1) E_{AS} Test Circuits



2) Gate Charge Test Circuit

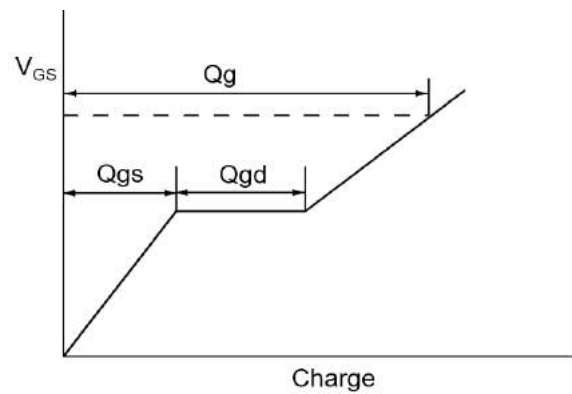
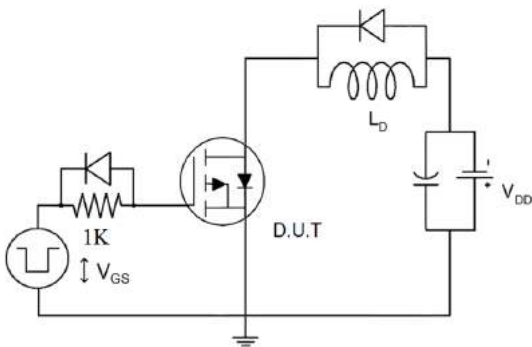

3) Switch Time Test Circuit

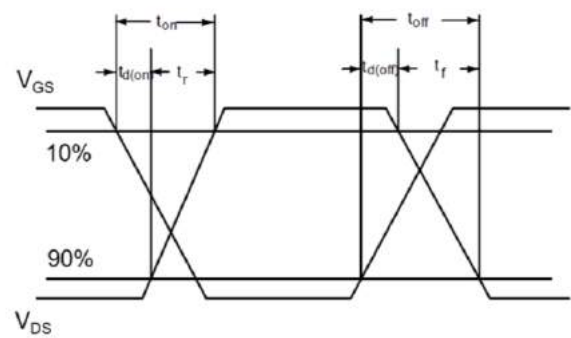
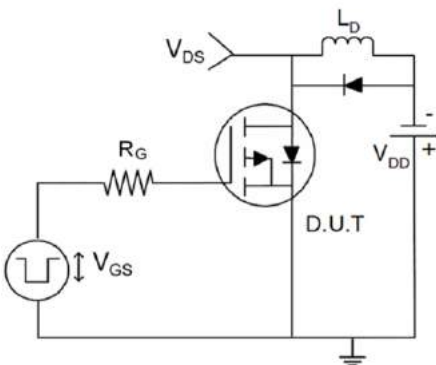

TO-252 Package Information

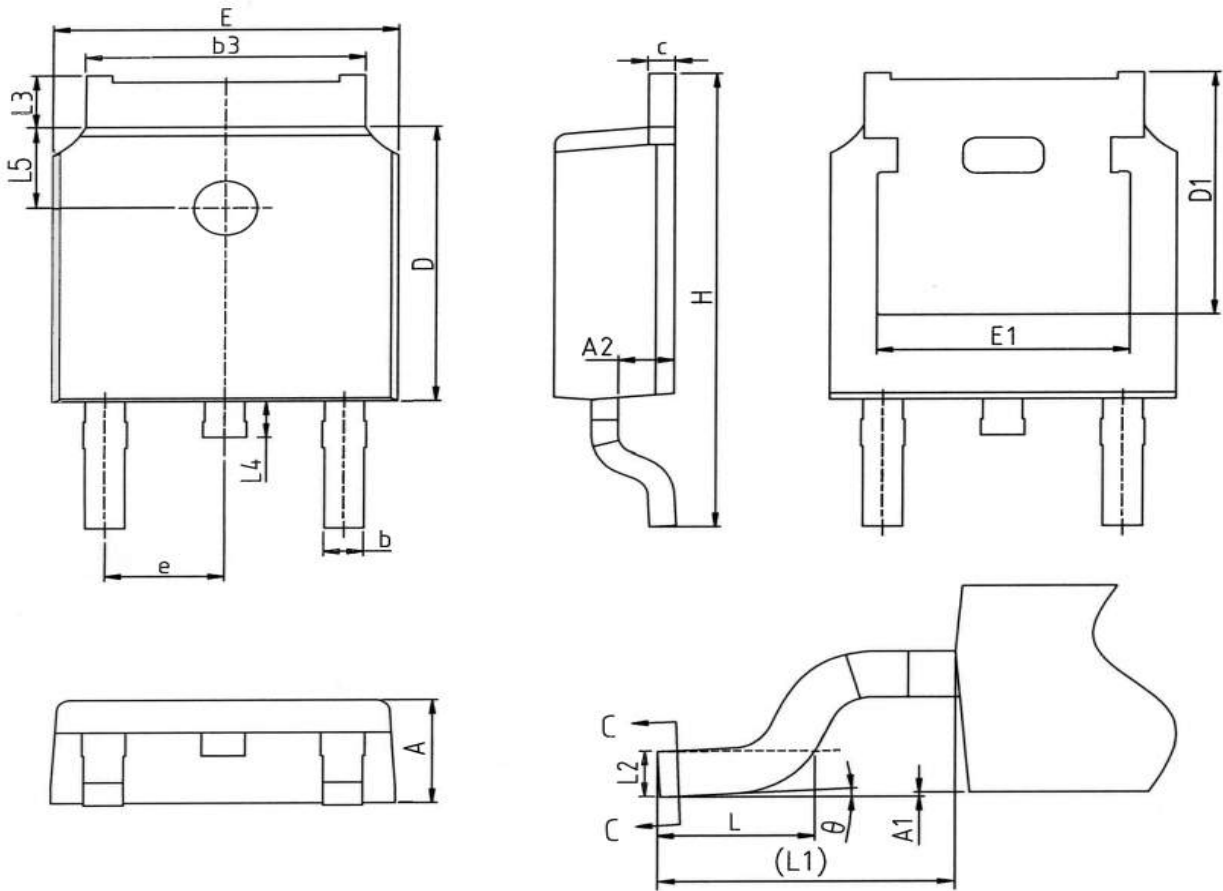

SYMBOL	mm		
	MIN	NOM	MAX
A	2.20	2.30	2.38
A1	0.00	-	0.12
A2	0.97	1.07	1.17
b	0.68	0.78	0.90
b3	5.20	5.33	5.46
c	0.43	0.53	0.61
D	5.98	6.10	6.22
D1	5.30REF		
E	6.40	6.60	6.73
E1	4.63	-	-
e	2.286BSC		
H	9.40	10.10	10.50
L	1.38	1.50	1.75
L1	2.90REF		
L2	0.51BSC		
L3	0.88	-	1.28
L4	0.50	-	1.00
L5	1.65	1.80	1.95
θ	0°	-	8°

Customer Service

Sales and Service:

zj@ztasemi.com