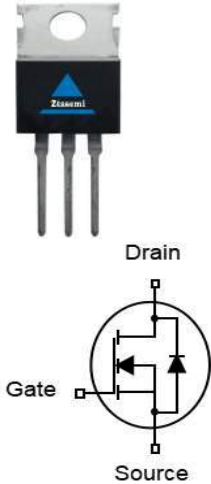

Features

- N-Channel
- 100% Avalanche Tested
- Reliable and Rugged
- Lead-Free and Green Devices Available
- RoHS Compliant
- 100% EAS Tested

V_{DS}	100	V
$R_{DS(on),TYP}@ V_{GS}=10V$	3.2	m Ω
I_D	120	A

TO-220

Part ID	Package Type	Marking	Packing
ZTG033N10	TO-220	ZTG033N10	1000pcs/Tape

Absolute Maximum Ratings $T_A = 25^\circ\text{C}$, unless otherwise specified

Symbol	Parameter	Rating	Unit	
Common Ratings ($T_c=25^\circ\text{C}$ Unless Otherwise Noted)				
V_{GS}	Gate-Source Voltage	± 20	V	
$V_{(BR)DSS}$	Drain-Source Breakdown Voltage	100	V	
T_J	Maximum Junction Temperature	150	$^\circ\text{C}$	
T_{STG}	Storage Temperature Range	-55 to 150	$^\circ\text{C}$	
I_{DM}	Drain Current-Continuous@ Current-Pulsed (Note 1)	$T_c = 25^\circ\text{C}$ 480	A	
Mounted on Large Heat Sink				
I_D	Drain Current-Continuous	$T_c = 25^\circ\text{C}$	120	A
		$T_c = 100^\circ\text{C}$	110	A
P_D	Maximum Power Dissipation	$T_c = 25^\circ\text{C}$	210	W
$R_{\theta JC}$	Thermal Resistance-Junction to Case		0.6	$^\circ\text{C}/\text{W}$
$R_{\theta JA}$	Thermal Resistance Junction-Ambient		62.5	$^\circ\text{C}/\text{W}$
Drain-Source Avalanche Ratings				
EAS	Avalanche Energy, Single Pulsed (Note 1)		780	mJ

Electrical Characteristics (T_J=25°C unless otherwise noted)

Symbol	Parameter	Condition	Min	Typ	Max	Unit
Static Electrical Characteristics @ T_J=25°C (unless otherwise stated)						
V(BR)DSS	Drain-Source Breakdown Voltage	V _{GS} =0V, I _D =250μA	100	--	--	V
IDSS	Zero Gate Voltage Drain Current	V _{DS} =100V, V _{GS} =0V	--	--	1	μA
IGSS	Gate-Body Leakage Current	V _{GS} =±20V, V _{DS} =0V	--	--	±100	nA
VGS(th)	Gate Threshold Voltage	V _{DS} =V _{GS} , I _D =250μA	2.0	3.0	4.0	V
RDS(on)	Drain-Source On-State Resistance	V _{GS} =10V, I _D =50A	--	3.2	4.0	mΩ
Dynamic Electrical Characteristics @ T_J = 25°C (unless otherwise stated) (Note 2,3)						
Ciss	Input Capacitance	V _{DS} =50V, V _{GS} =0V, f=0.5MHz	--	6550	--	pF
Coss	Output Capacitance		--	902	--	pF
Crss	Reverse Transfer Capacitance		--	20	--	pF
Qg	Total Gate Charge	V _{DD} =50V, I _D =20A, V _{GS} =10V	--	113	--	nC
Qgs	Gate-Source Charge		--	38	--	nC
Qgd	Gate-Drain Charge		--	29	--	nC
Switching Characteristics						
Td(on)	Turn-on Delay Time	V _{DD} =50V, I _D =50A, R _G =3Ω, V _{GS} =10V	--	32	--	ns
Tr	Turn-on Rise Time		--	54	--	ns
Td(off)	Turn-Off Delay Time		--	75	--	ns
Tf	Turn-Off Fall Time		--	25	--	ns
Source- Drain Diode Characteristics @ T_J = 25°C (unless otherwise stated)						
ISD	Source-Drain Current (Body Diode)		--	--	120	A
VSD	Forward on voltage	I _S =50A, V _{GS} =0V	--	--	1.4	V
Trr	Reverse Recovery Time	T _J =25°C, I _F =50A, di/dt=100A/μs	--	79	--	ns
Qrr	Reverse Recovery Charge		--	0.2	--	uC

Notes:

1. L=0.5mH, I_{AS}=56A, R_G=25Ω, V_{DD}=80V, Start T_J=25°C.
2. Pulse test: pulse width ≤ 300μs, Duty Cycle ≤ 2%.
3. Basically not affected by the operating temperature.

Typical Electrical and Thermal Characteristics

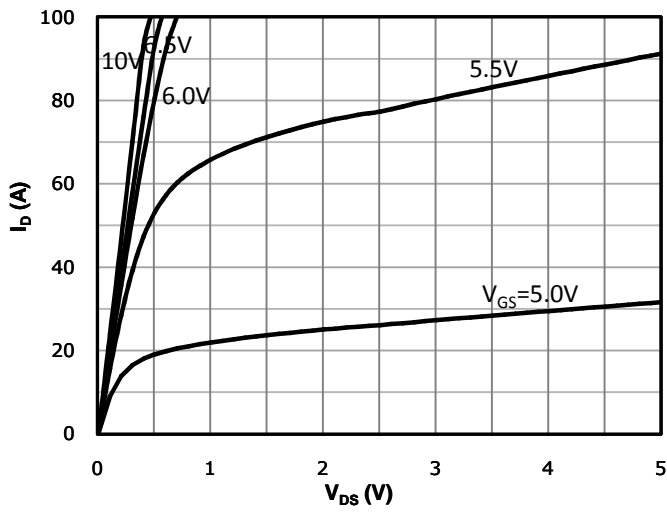

Fig 1: Output Characteristics

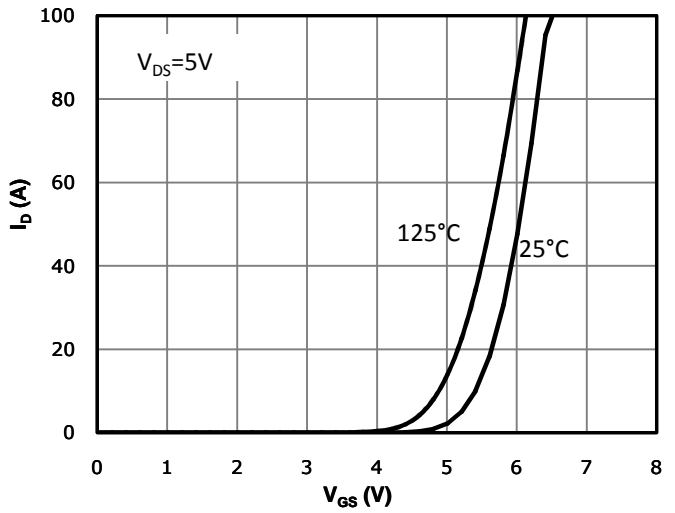

Fig 4: Transfer Characteristics

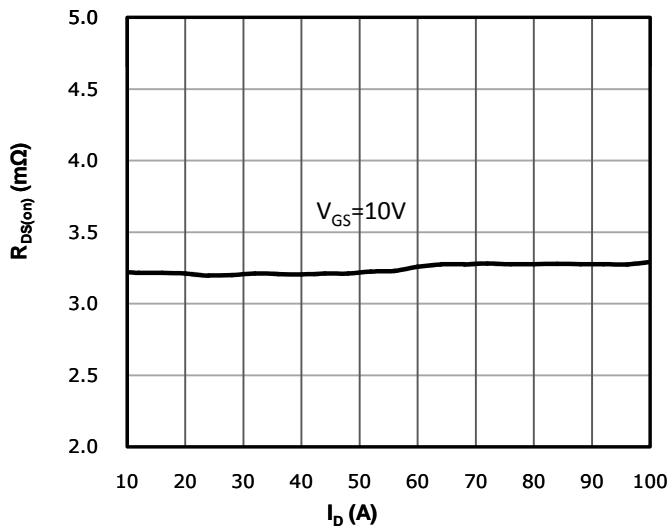

Fig 2: Rds(on) vs Drain Current and Gate Voltage

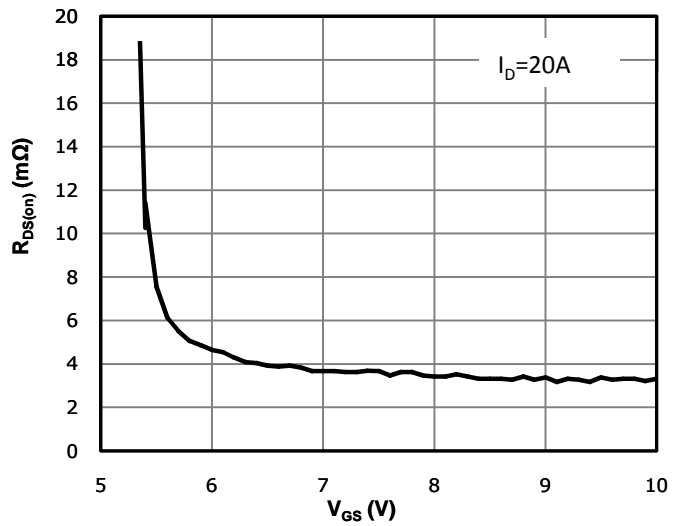

Fig 5: Rds(on) vs Gate Voltage

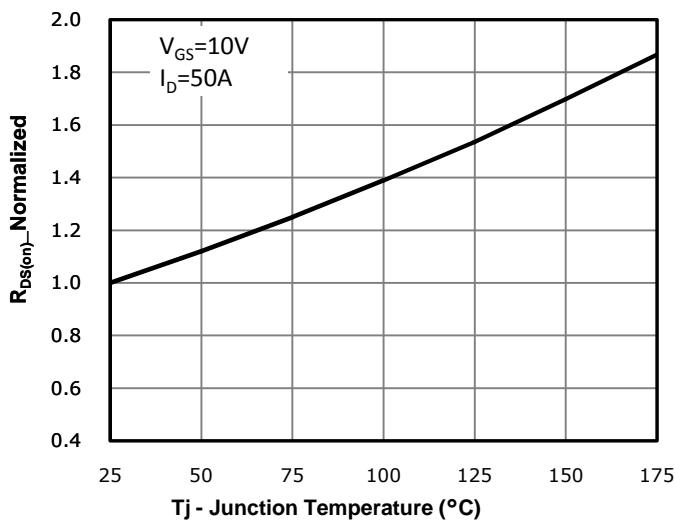

Fig 3: Rds(on) vs. Temperature

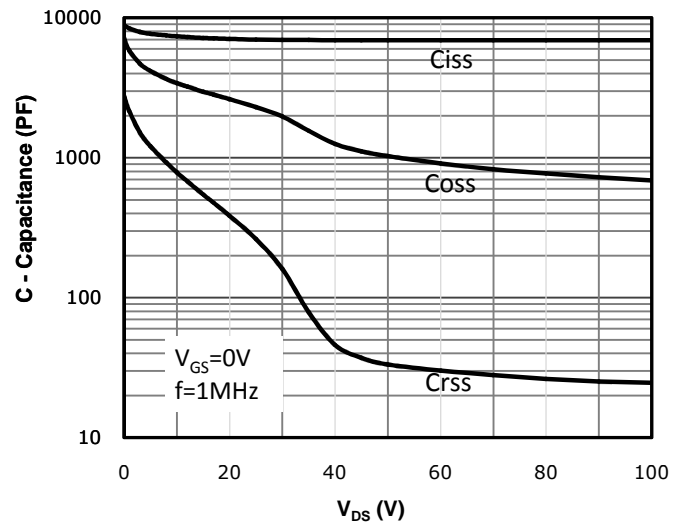

Fig 6: Capacitance Characteristics

Typical Electrical and Thermal Characteristics

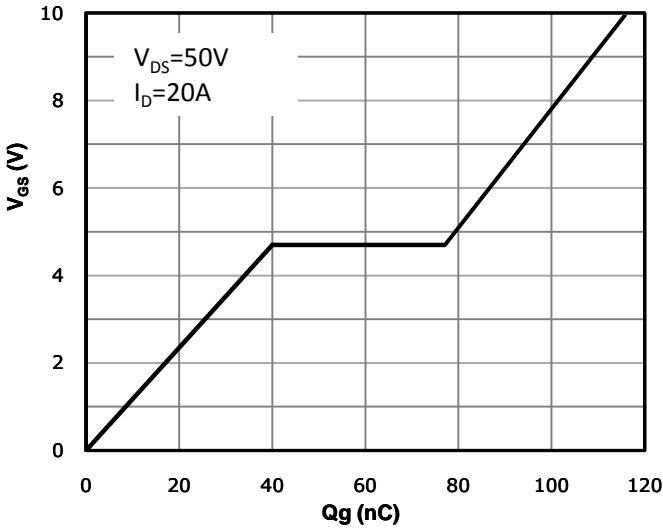

Fig 7: Gate Charge Characteristics

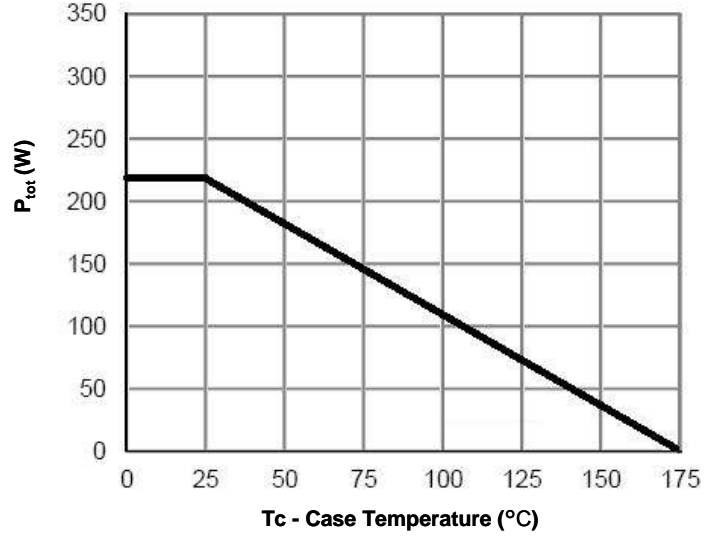

Fig 9: Power Dissipation

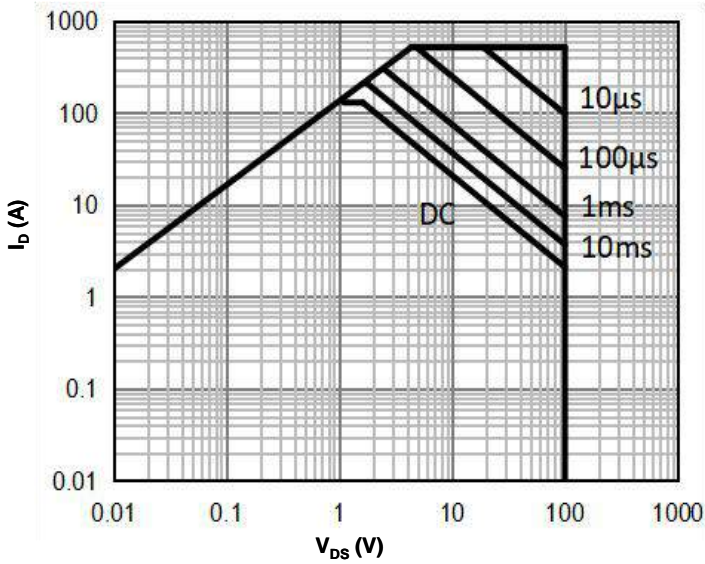

Fig 8: Safe Operating Area

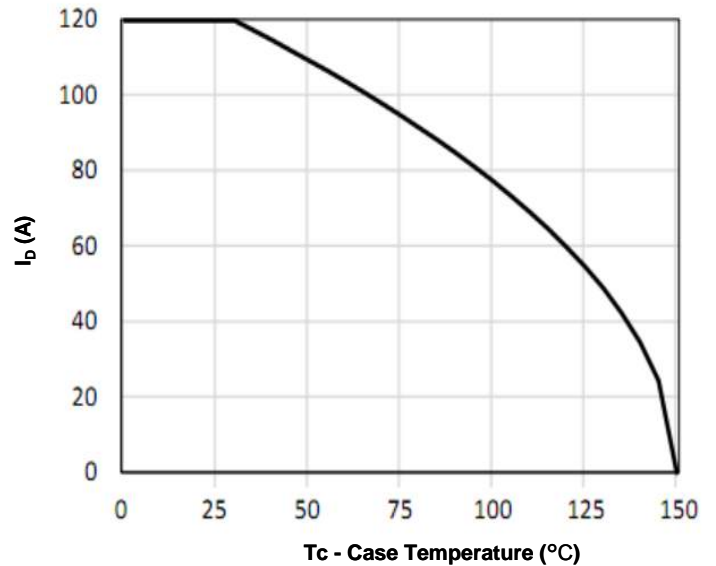

Fig 10: Drain Current Derating

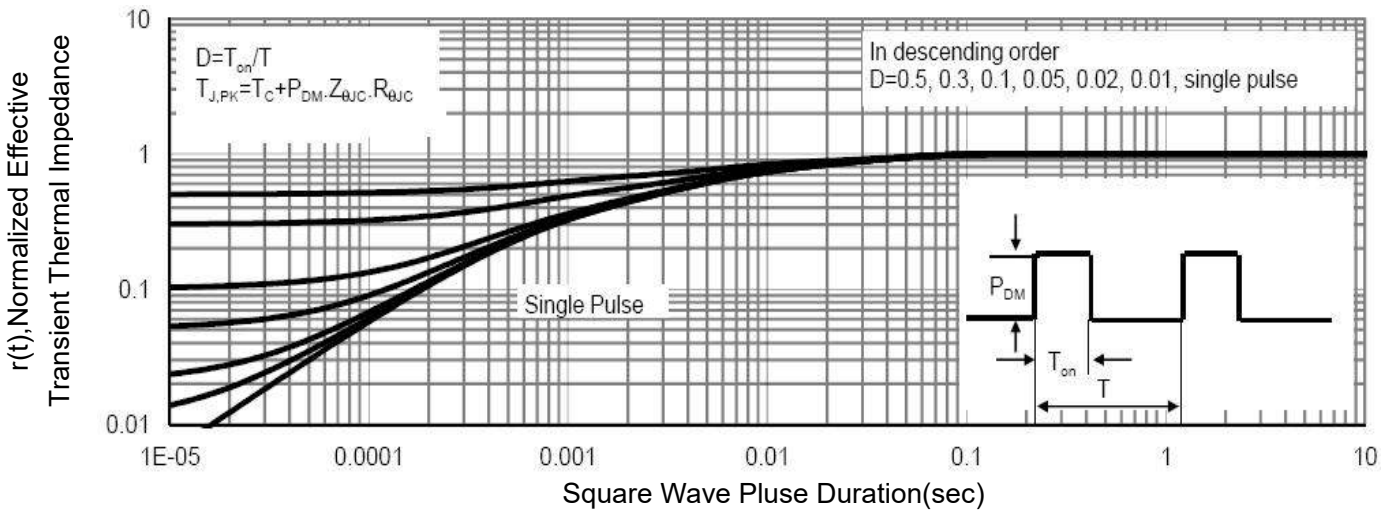

Fig 11: Max. Transient Thermal Impedance

Figure A: Gate Charge Test Circuit and Waveform

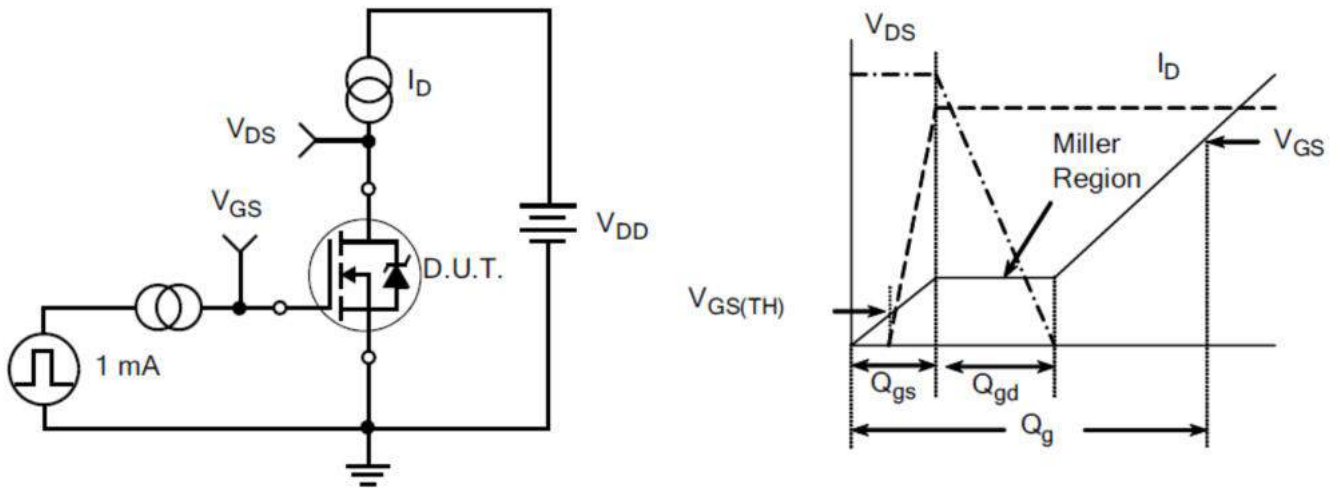

Figure B: Resistive Switching Test Circuit and Waveform

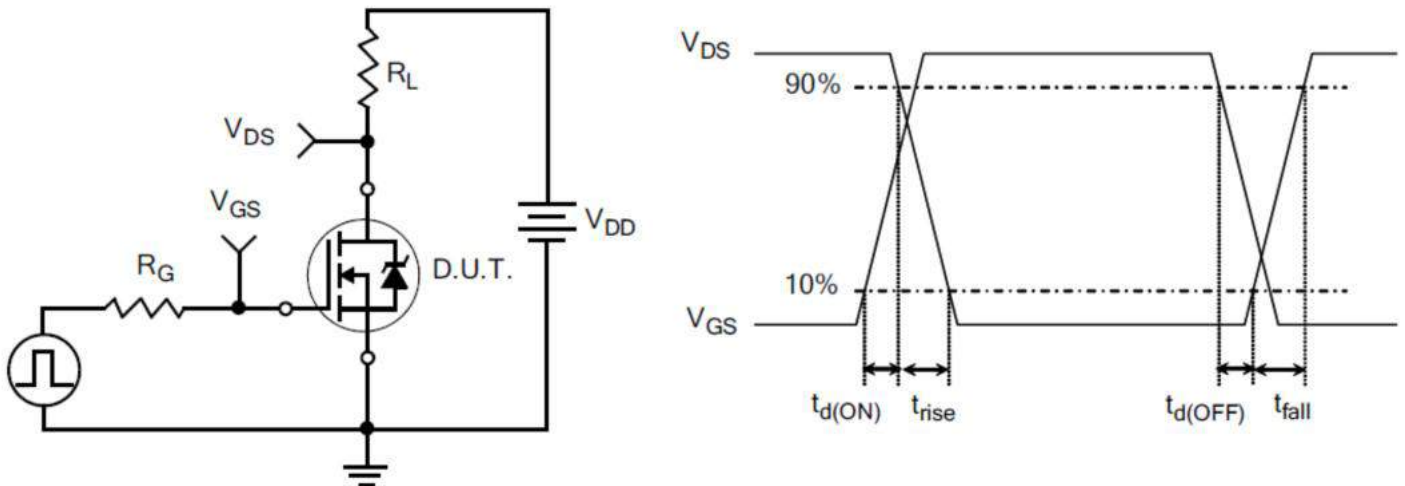
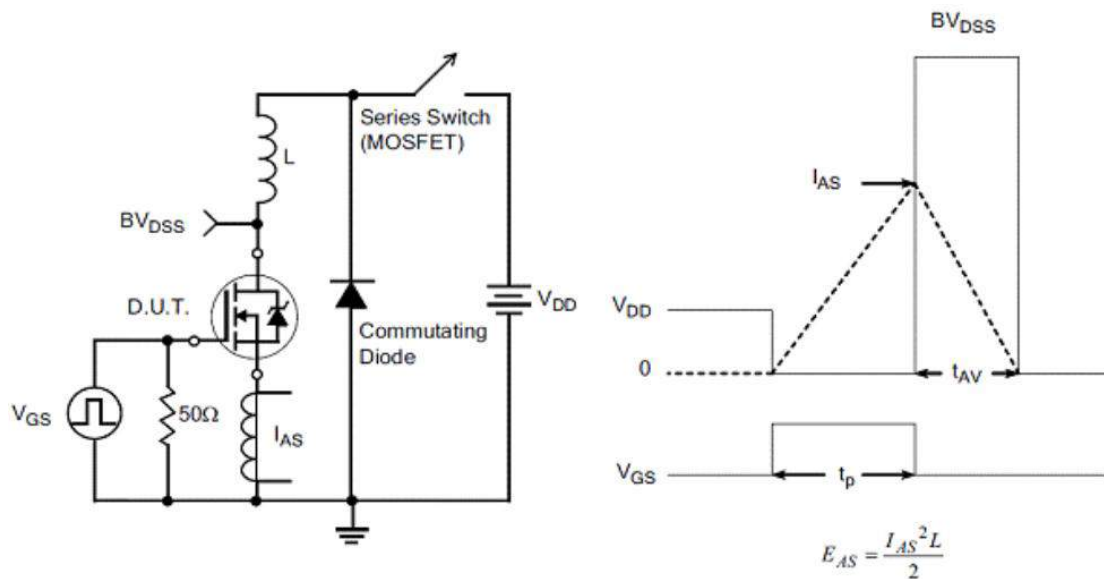
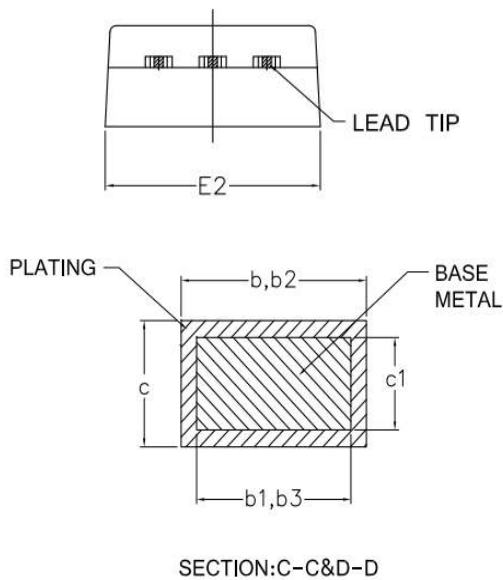
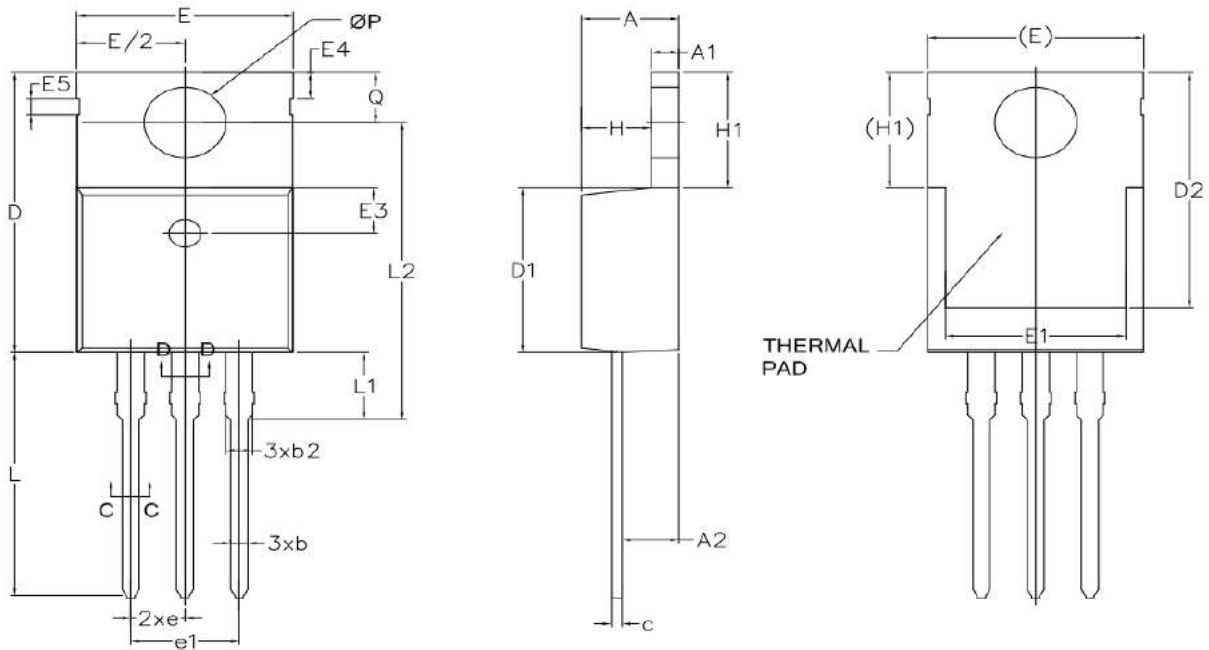

Figure C: Unclamped Inductive Switching Test Circuit and Waveform



TO-220-3L Package Information



SYMBOLS	COMMON		
	MM		
	MIN.	NOM.	MAX.
A	4.47	4.57	4.67
A1	1.20	1.30	1.40
A2	2.35	2.67	2.90
b	0.71	0.80	0.91
b1	0.71	0.80	0.86
b2	1.22	1.27	1.36
b3	1.22	1.27	1.31
c	0.47	0.50	0.60
c1	0.47	0.50	0.55
D	14.70	15.30	15.80
D1	8.90	9.00	9.47
D2	11.75	/	13.60
E	9.70	/	10.37
E1	7.00	8.44	8.89
E2	9.80	10.11	10.20
E3	2.40	2.50	2.60
E4	1.27	1.42	1.57
E5	0.90TYP		
e	2.54BSC		
e1	5.08BSC		
H	3.00	3.27	3.40
H1	6.15	6.30	6.45
L	12.90	13.45	14.80
L1	2.54	3.69	3.84
L2	12.13	16.25	16.5
∅P	3.60	3.84	3.90
Q	2.65	2.74	2.95

Customer Service

Sales and Service:

zj@ztasemi.com