

Features

- N-Channel
- Low $R_{DS(on)}$ & FOM
- Extremely low switching loss
- Excellent reliability and uniformity
- Fast switching and soft recovery
- 100% EAS Tested

V_{DS}	30	V
$R_{DS(on),TYP@ V_{GS}=10V}$	1.8	$m\Omega$
$R_{DS(on),TYP@ V_{GS}=4.5V}$	3.0	$m\Omega$
I_D	95	A

DFN5x6



Part ID	Package Type	Marking	Packing
ZTG020N03GC	DFN5x6	ZTG020N03GC	5000pcs/Reel

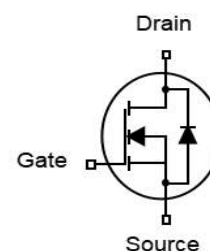

Absolute Maximum Ratings $T_A = 25^\circ\text{C}$, unless otherwise specified

Symbol	Parameter	Rating	Unit	
Common Ratings ($T_C = 25^\circ\text{C}$ Unless Otherwise Noted)				
V_{GS}	Gate-Source Voltage	± 20	V	
$V_{(BR)DSS}$	Drain-Source Breakdown Voltage	30	V	
T_J	Maximum Junction Temperature	150	$^\circ\text{C}$	
T_{STG}	Storage Temperature Range	-55 to 150	$^\circ\text{C}$	
I_{DM}	Drain Current-Continuous@ Current-Pulsed (Note 1)	$T_C = 25^\circ\text{C}$ 380	A	
Mounted on Large Heat Sink				
I_D	Drain Current-Continuous	$T_C = 25^\circ\text{C}$	95	A
		$T_C = 100^\circ\text{C}$	60	A
P_D	Maximum Power Dissipation (Note 2)	90	W	
$R_{\theta JC}$	Thermal Resistance-Junction to Case	1.36	$^\circ\text{C}/\text{W}$	
$R_{\theta JA}$	Thermal Resistance Junction-Ambient (Note 3)	50	$^\circ\text{C}/\text{W}$	
Drain-Source Avalanche Ratings				
EAS	Avalanche Energy, Single Pulsed (Note 7)	156	mJ	

Electrical Characteristics (T_J=25°C unless otherwise noted)

Symbol	Parameter	Condition	Min	Typ	Max	Unit
Static Electrical Characteristics @ T_J=25°C (unless otherwise stated)						
V(BR)DSS	Drain-Source Breakdown Voltage	V _{GS} =0V, I _D =250μA	30	--	--	V
I _{DSS}	Zero Gate Voltage Drain Current	V _{DS} =30V, V _{GS} =0V	--	--	1	μA
I _{GSS}	Gate-Body Leakage Current	V _{GS} =±20V, V _{DS} =0V	--	--	±100	nA
V _{GS(th)}	Gate Threshold Voltage	V _{DS} =V _{GS} , I _D =250μA	1.0	1.9	2.2	V
R _{DS(on)}	Drain-Source On-State Resistance	V _{GS} =10V, I _D =20A	--	1.8	2.4	mΩ
R _{DS(on)}	Drain-Source On-State Resistance	V _{GS} =4.5V, I _D =15A	--	3.0	3.8	mΩ
Dynamic Electrical Characteristics @ T_J = 25°C (unless otherwise stated) (Note 5)						
C _{iss}	Input Capacitance	V _{DS} =15V, V _{GS} =0V, f=1MHz	--	2565	--	pF
C _{oss}	Output Capacitance		--	1419	--	pF
C _{rss}	Reverse Transfer Capacitance		--	111	--	pF
R _g	Gate Resistance	f=1MHz	--	2.6	--	Ω
Q _g	Total Gate Charge	V _{DS} =15V, I _D =20A, V _{GS} =10V	--	38	--	nC
Q _{gs}	Gate-Source Charge		--	11	--	nC
Q _{gd}	Gate-Drain Charge		--	4.5	--	nC
Switching Characteristics (Note 5)						
T _{d(on)}	Turn-on Delay Time	V _{DD} =20V, I _D =20A, R _G =3.0Ω, V _{GS} =10V	--	10	--	ns
T _r	Turn-on Rise Time		--	37	--	ns
T _{d(off)}	Turn-Off Delay Time		--	45	--	ns
T _f	Turn-Off Fall Time		--	16	--	ns
Source- Drain Diode Characteristics @ T_J = 25°C (unless otherwise stated)						
I _S	Diode Forward Current (Note 3)		--	--	95	A
V _{SD}	Forward on voltage (Note 6)	I _S =20A, V _{GS} =0V	--	--	1.4	V
T _{rr}	Reverse Recovery Time (Note 4)	T _J =25°C, I _S = I _F di/dt=100A/μs	--	49	--	ns
Q _{rr}	Reverse Recovery Charge		--	35	--	nC

Notes:

1. Repetitive Rating: Pulse width limited by maximum junction temperature. Ratings are based on low frequency and duty cycles to keep initial T_J=25° C.
2. The power dissipation PD is based on T_{J(MAX)}=150°C, using junction-to-case thermal resistance.
3. Surface Mounted on 1in2 FR-4 board with 2oz. Copper, in a still air environment with T_A=25°C.
4. Pulse Test: Pulse Width ≤ 300μs, Duty Cycle ≤ 2%.
5. Guaranteed by design, not subject to production.
6. The maximum current limited by package
7. EAS condition : T_J=25°C, V_{DD}=15V, V_G=10V, L=0.5mH, R_g=25Ω

TYPICAL ELECTRICAL AND THERMAL CHARACTERISTICS

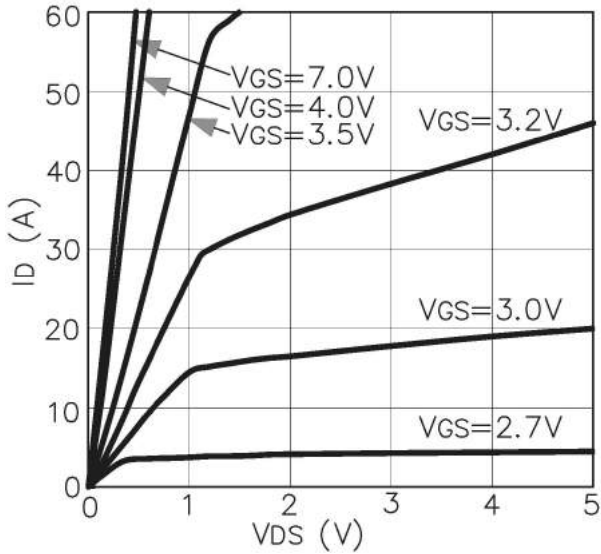

Figure 1 Output Characteristics

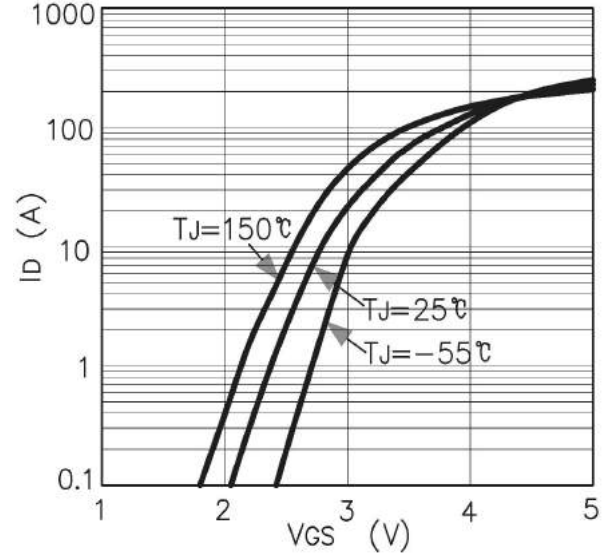

Figure 4 Transfer Characteristics

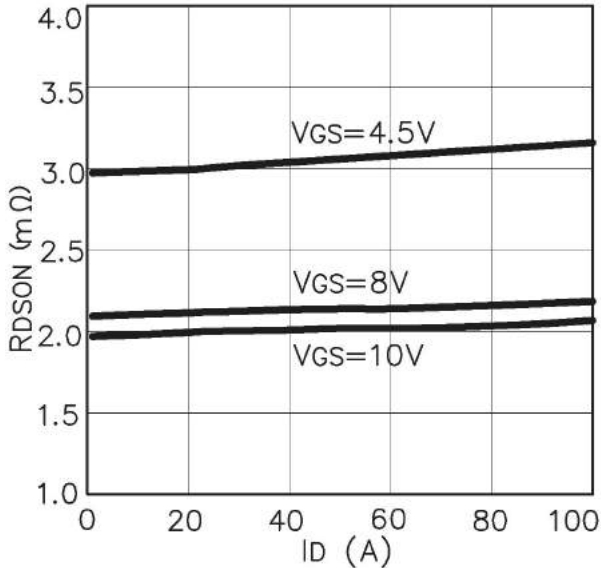

Figure 2 Rdson- Drain Current

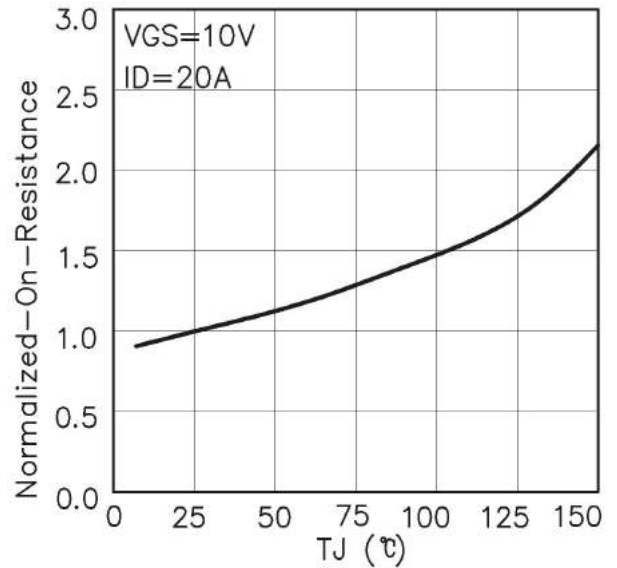

Figure 5 Rdson-Junction Temperature

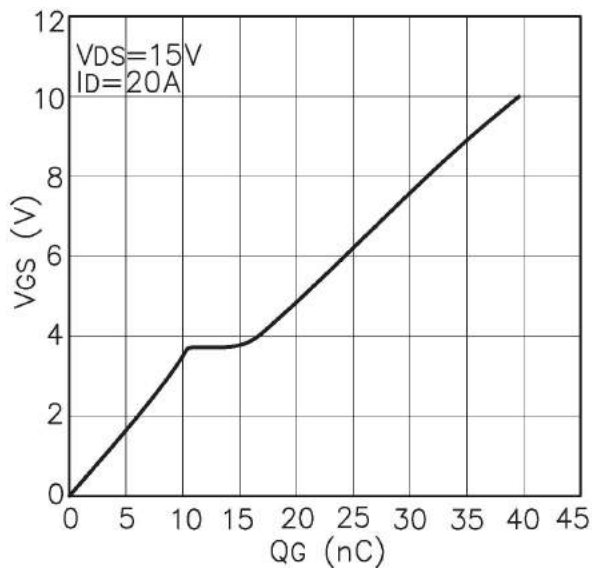

Figure 3 Gate Charge

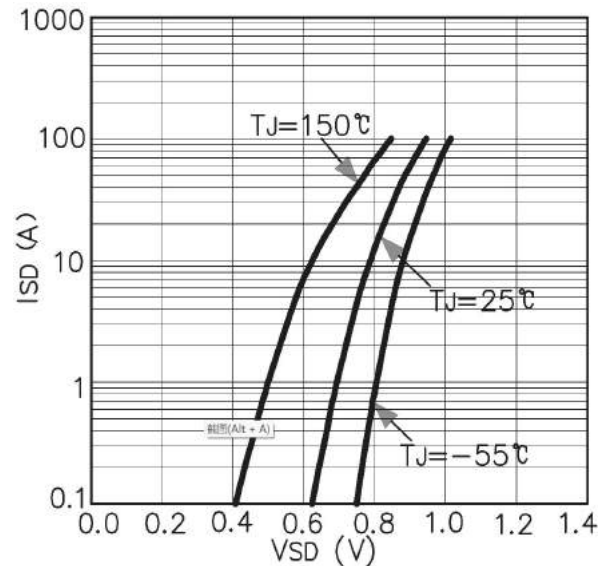

Figure 6 Source- Drain Diode Forward

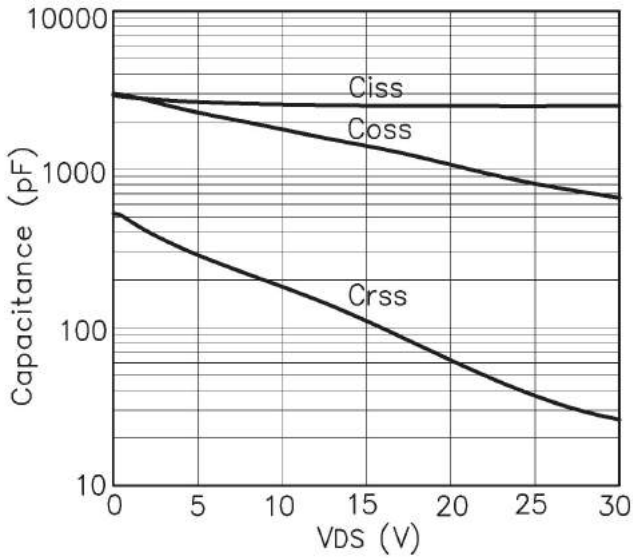

Figure 7 Capacitance vs Vds

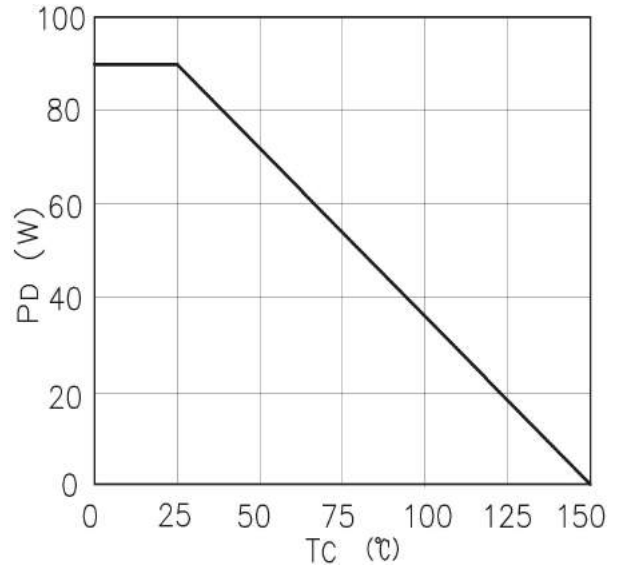

Figure 9 Power De-rating

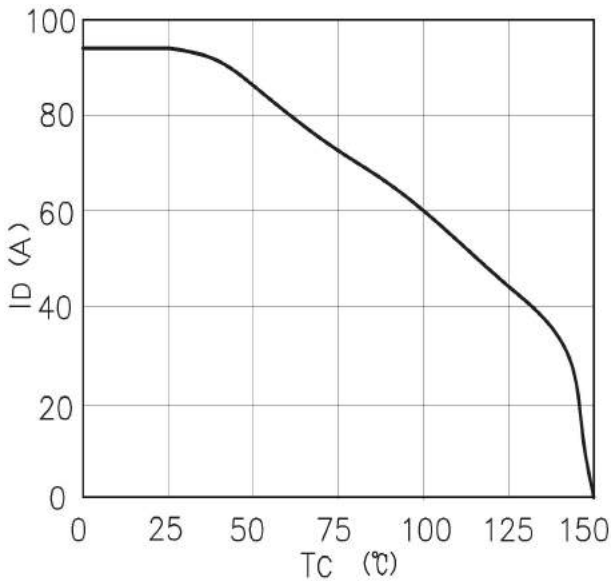

Figure 8 Current De-rating

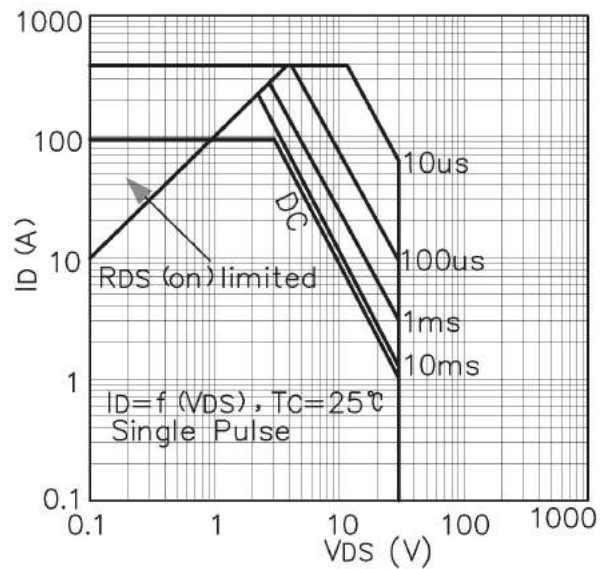

Figure 10 Safe Operation Area

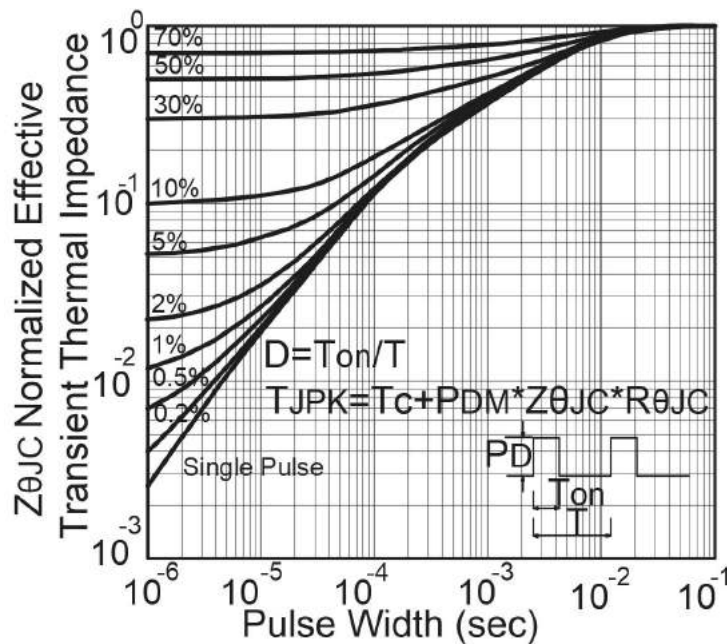
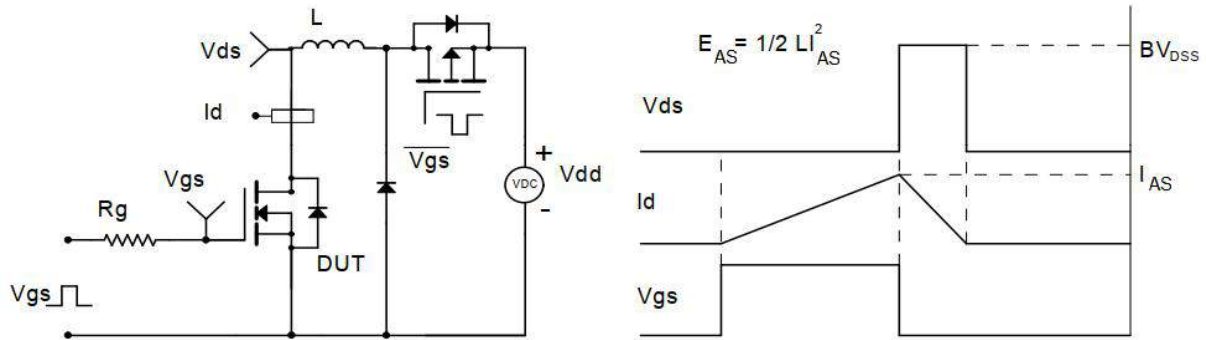

Figure 11 Normalized Maximum Transient Thermal Impedance

Test circuit&Waveform

Unclamped Inductive Switching (UIS) Test Circuit & Waveforms



Gate Charge Test Circuit & Waveform

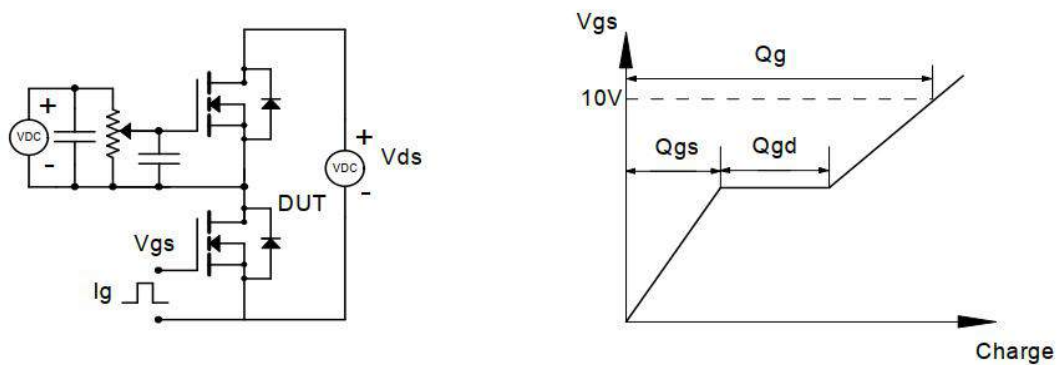

Resistive Switching Test Circuit & Waveforms

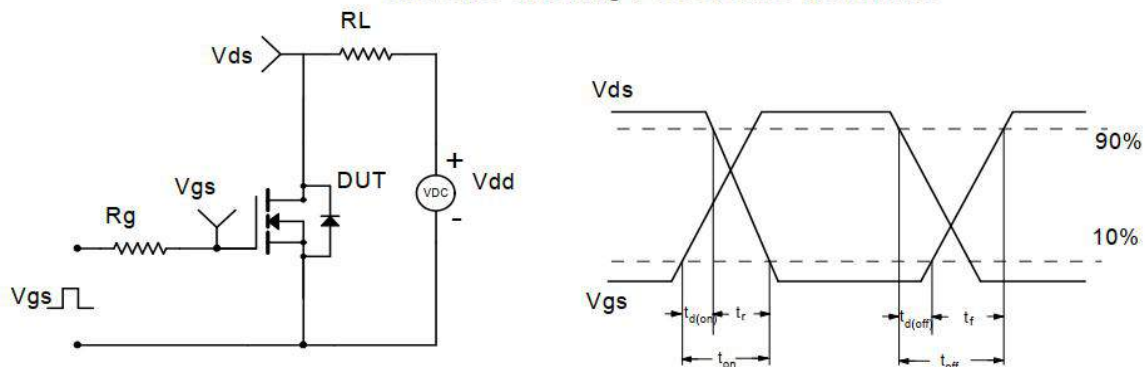

Diode Recovery Test Circuit & Waveforms

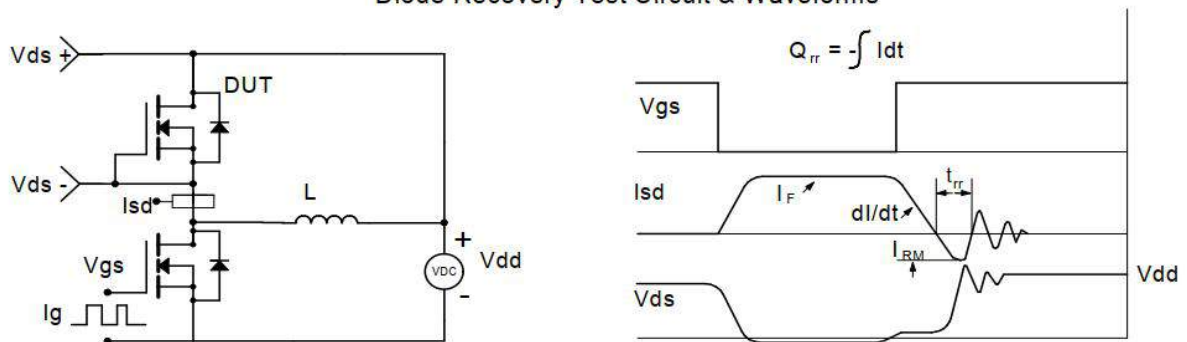

DFN5x6-8L Package Information

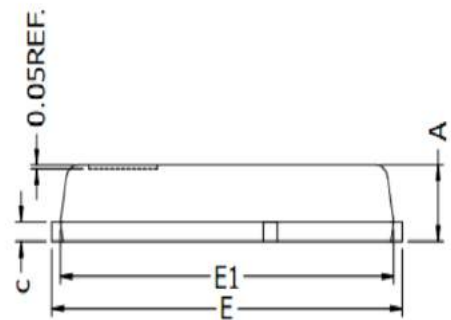
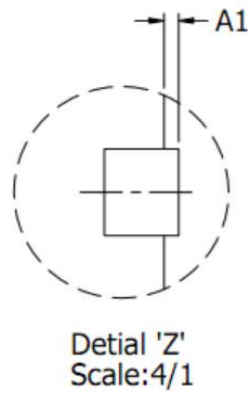
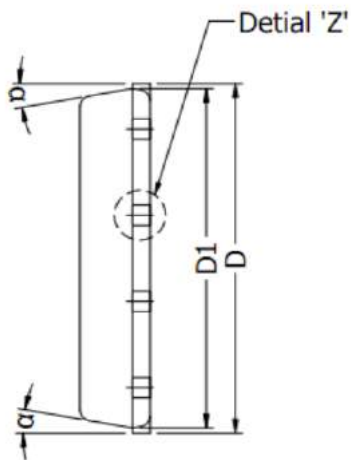
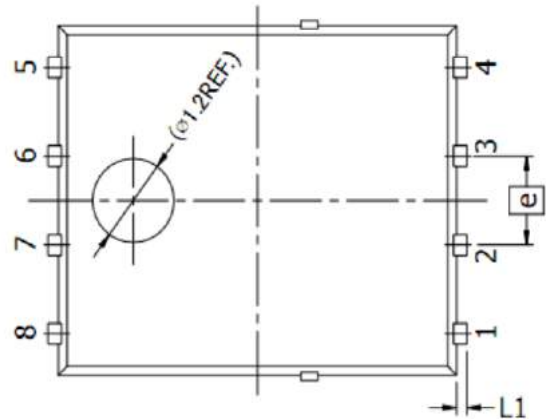
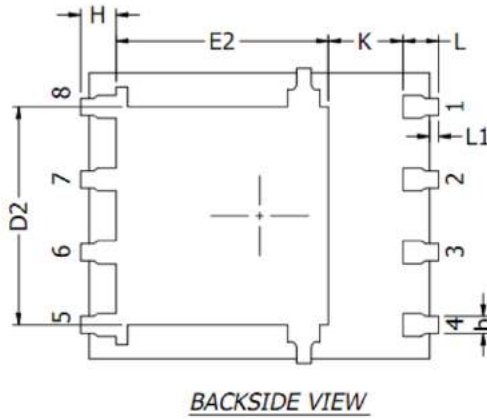

DIM.	MILLIMETERS		
	MIN.	NOM.	MAX.
A	0.90	1.00	1.10
A1	0	-	0.05
b	0.30	0.40	0.50
c	0.20	0.25	0.30
D	5.15 BSC		
D1	5.00 BSC		
D2	3.76	3.81	3.86
E	6.15 BSC		
E1	5.80	5.85	5.90
E2	3.45	3.65	3.85
e	1.27 BSC		
H	0.51	0.61	0.71
K	1.10	-	-
L	0.51	0.61	0.71
L1	0.08	0.15	0.23
α	10°	11°	12°

Customer Service

Sales and Service:
zj@ztasemi.com