

Features

- N-Channel
- Advanced Trench Technology
- Excellent Gate Charge \times $R_{DS(on)}$ (FOM)
- low on -resistance
- RoHS compliant
- Halogen -free
- 100% EAS Tested

V_{DS}	30	V
$R_{DS(on),TYP@ V_{GS}=10V}$	1.9	$m\Omega$
$R_{DS(on),TYP@ V_{GS}=4.5V}$	3.8	$m\Omega$
I_D	100	A

DFN5x6

Part ID	Package Type	Marking	Packing
ZT019N03G	DFN5x6	ZT019N03G	5000pcs/reel

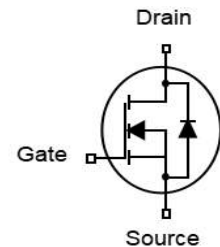

Absolute Maximum Ratings $T_A = 25^\circ\text{C}$, unless otherwise specified

Symbol	Parameter	Rating	Unit	
Common Ratings ($T_C=25^\circ\text{C}$ Unless Otherwise Noted)				
V_{GS}	Gate-Source Voltage	± 20	V	
$V_{(BR)DSS}$	Drain-Source Breakdown Voltage	30	V	
T_J	Maximum Junction Temperature	150	$^\circ\text{C}$	
T_{STG}	Storage Temperature Range	-55 to 150	$^\circ\text{C}$	
I_{DM}	Drain Current-Continuous@ Current-Pulsed (Note 3)	$T_C = 25^\circ\text{C}$ 400	A	
Mounted on Large Heat Sink				
I_D	Drain Current-Continuous (Note 2)	$T_C = 25^\circ\text{C}$	100	A
		$T_C = 100^\circ\text{C}$	76	A
P_D	Maximum Power Dissipation	136	W	
$R_{\theta JC}$	Thermal Resistance-Junction to Case	0.9	$^\circ\text{C/W}$	
$R_{\theta JA}$	Thermal Resistance Junction-Ambient	42	$^\circ\text{C/W}$	
Drain-Source Avalanche Ratings				
EAS	Avalanche Energy, Single Pulsed (Note 1)	347	mJ	

Electrical Characteristics (T_J=25°C unless otherwise noted)

Symbol	Parameter	Condition	Min	Typ	Max	Unit
Static Electrical Characteristics @ T_J=25°C (unless otherwise stated)						
V(BR)DSS	Drain-Source Breakdown Voltage	V _{GS} =0V, I _D =250μA	30	--	--	V
IDSS	Zero Gate Voltage Drain Current	V _{DS} =30V, V _{GS} =0V	--	--	1	μA
IGSS	Gate-Body Leakage Current	V _{GS} =±20V, V _{DS} =0V	--	--	±100	nA
VGS(th)	Gate Threshold Voltage	V _{DS} =V _{GS} , I _D =250μA	1.0	1.5	2.1	V
RDS(on)	Drain-Source On-State Resistance	V _{GS} =10V, I _D =20A	--	1.9	2.8	mΩ
RDS(on)	Drain-Source On-State Resistance	V _{GS} =4.5V, I _D =20A	--	3.8	5.0	mΩ
Dynamic Electrical Characteristics @ T_J = 25°C (unless otherwise stated)						
Ciss	Input Capacitance	V _{DS} =15V, V _{GS} =0V, f=1MHz	--	3315	--	pF
Coss	Output Capacitance		--	473	--	pF
Crss	Reverse Transfer Capacitance		--	433	--	pF
Rg	Gate Resistance	f=1MHz	--	1.7	--	Ω
Qg	Total Gate Charge	V _{DS} =15V, I _D =30A, V _{GS} =10V	--	66	--	nC
Qgs	Gate-Source Charge		--	9.6	--	nC
Qgd	Gate-Drain Charge		--	13.1	--	nC
Switching Characteristics						
Td(on)	Turn-on Delay Time	V _{DS} =15V, I _D =30A, R _G =3.0Ω, V _{GS} =10V	--	5.1	--	ns
Tr	Turn-on Rise Time		--	24.8	--	ns
Td(off)	Turn-Off Delay Time		--	32.6	--	ns
Tf	Turn-Off Fall Time		--	23.9	--	ns
Source- Drain Diode Characteristics @ T_J = 25°C (unless otherwise stated)						
IS	Diode Forward Current		--	--	100	A
VSD	Forward on voltage	I _S =30A, V _{GS} =0V	--	--	1.2	V
Trr	Reverse Recovery Time	T _J =25°C, I _F =20A	--	22	--	ns
Qrr	Reverse Recovery Charge	di/dt=100A/μs	--	11	--	nC

Notes:

1. The max drain current rating is package limited
2. Repetitive Rating: Pulse width limited by maximum junction temperature
3. L = 0.5 mH, V_{DD} = 20V, I_{AS} = 20A, R_G = 25 Ω, Starting T_J = 25 °C
4. Mount on minimum PCB layout

Typical Characteristics $T_J = 25^\circ\text{C}$, unless otherwise noted

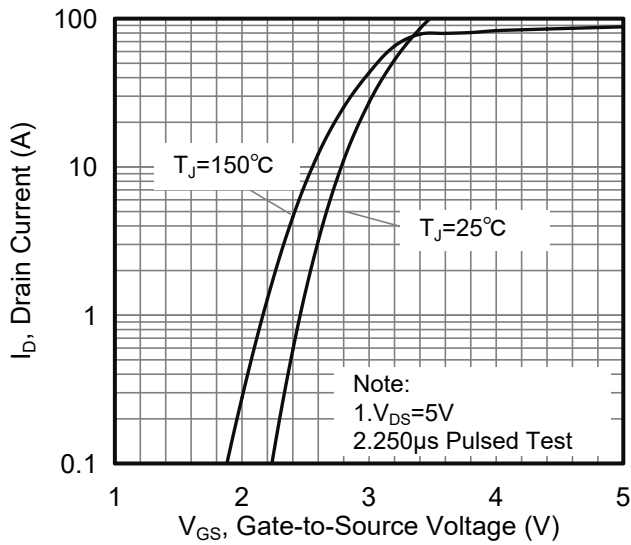

Figure 1. Typical Transfer Characteristics

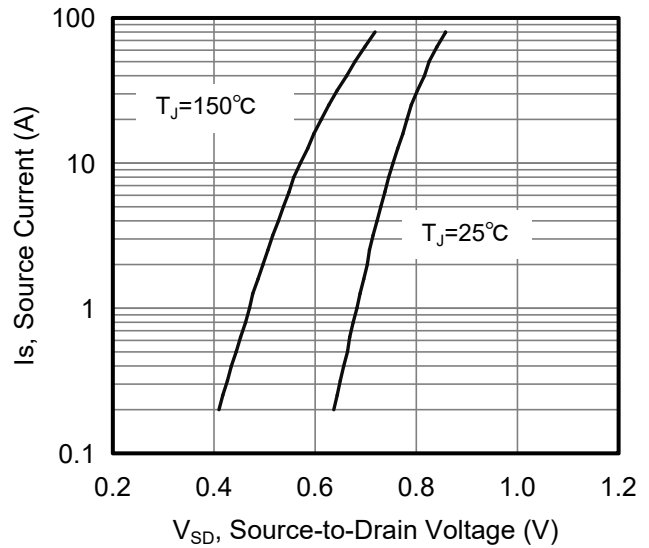

Figure 4. Typical Body Diode Transfer Characteristics

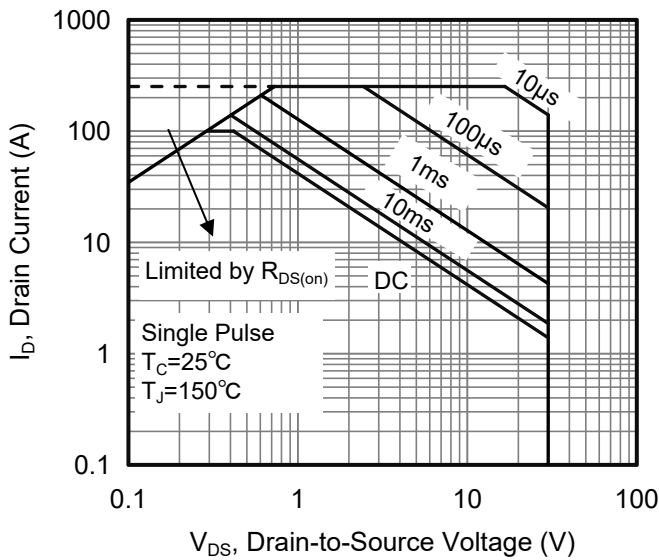

Figure 2. Maximum Safe Operating Area

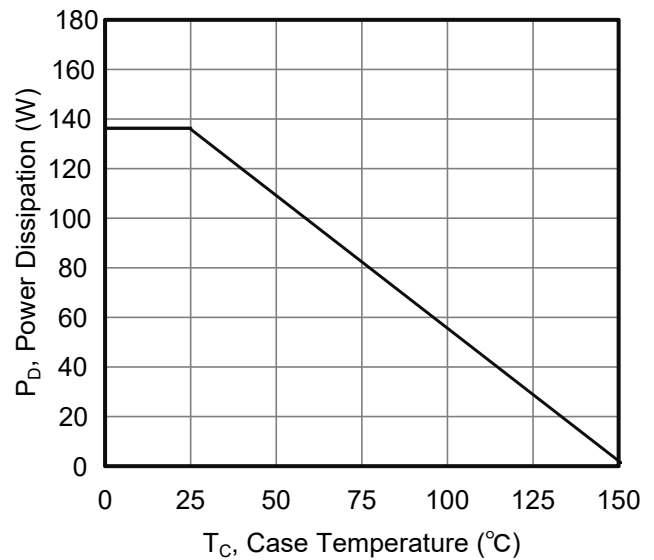

Figure 5. Maximum Power Dissipation vs Case Temperature

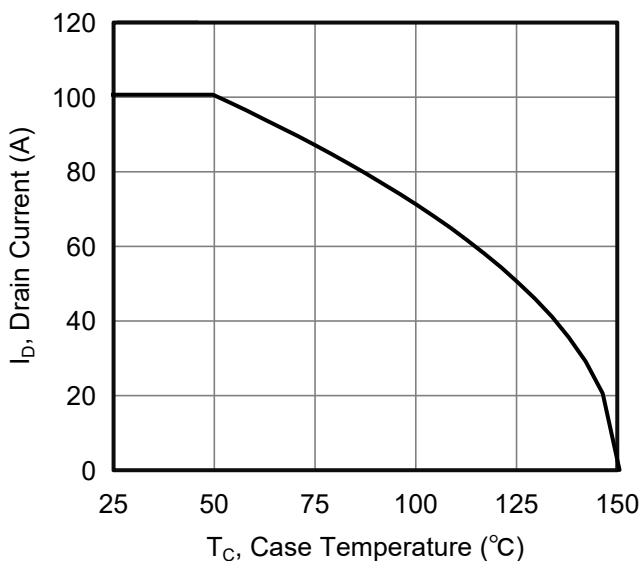

Figure 3. Maximum Continuous Drain Current vs Case Temperature

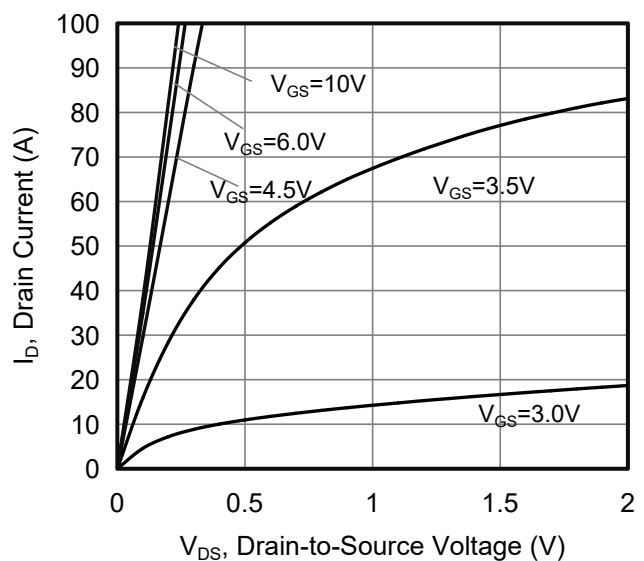

Figure 6. Typical output Characteristics

Typical Characteristics $T_J = 25^\circ\text{C}$, unless otherwise noted

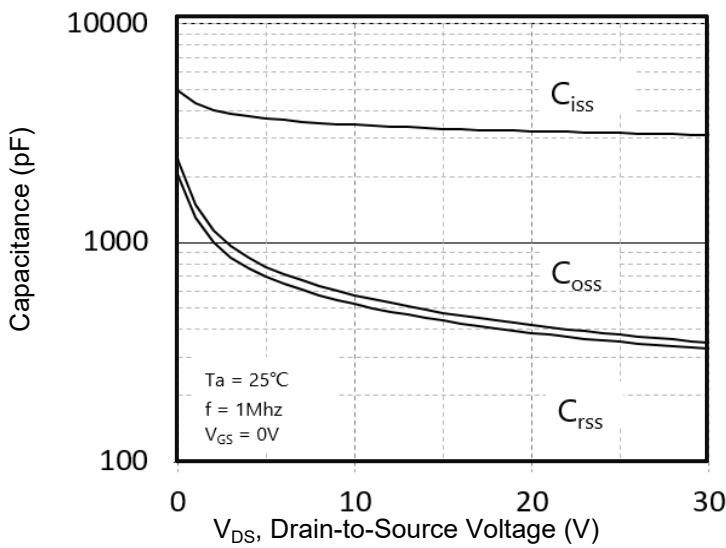

Figure 7 . Capacitance Characteristics

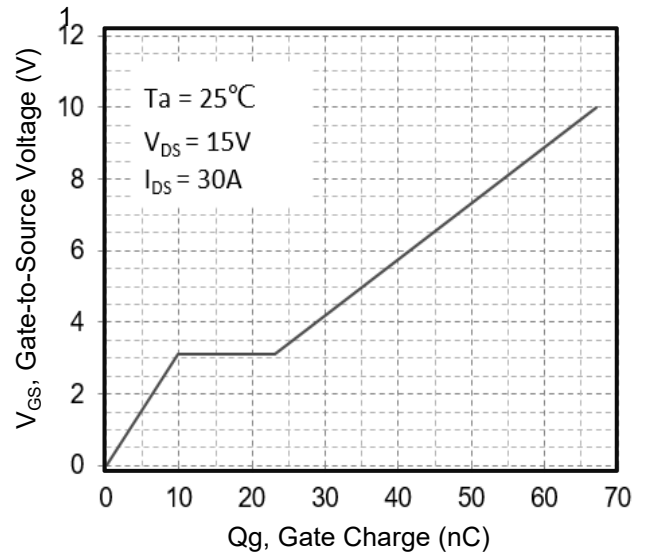

Figure 10. Typical Gate Charge vs Gate to Source Voltage

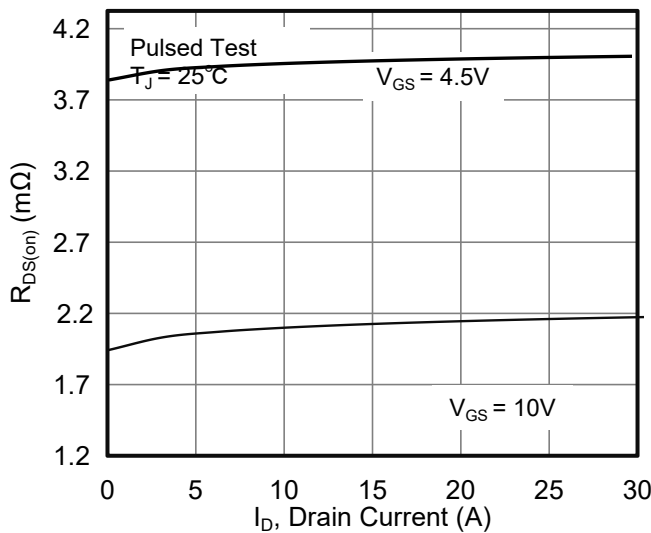

Figure 8. Drain-to-Source On Resistance vs Drain Current

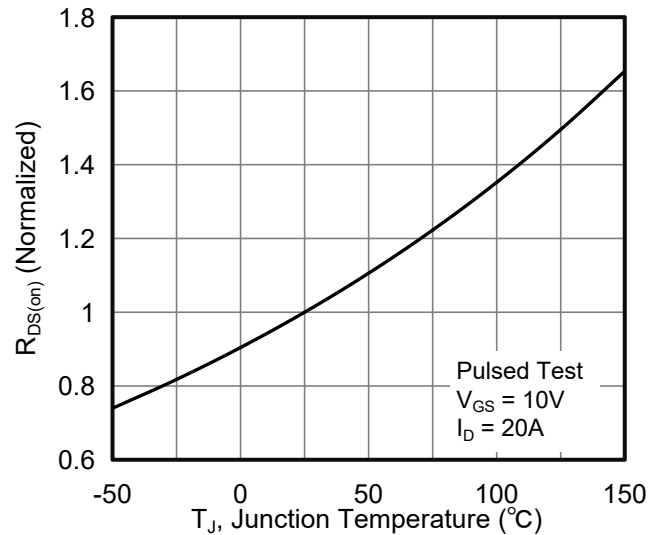

Figure 11. Normalized On Resistance vs Junction Temperature

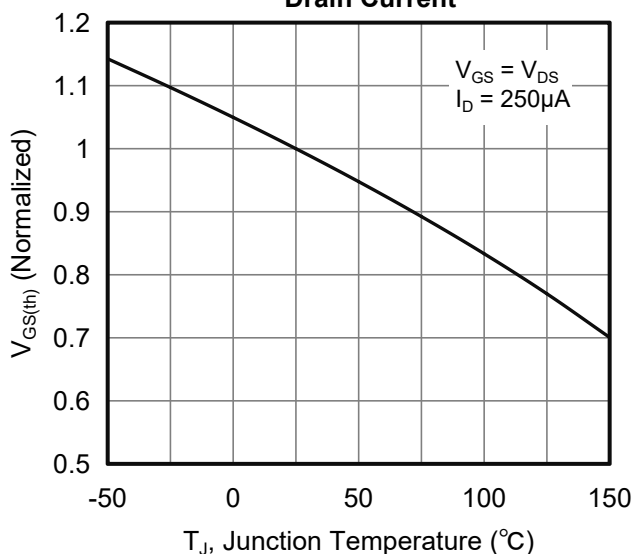

Figure 9 . Normalized Threshold Voltage vs Junction Temperature

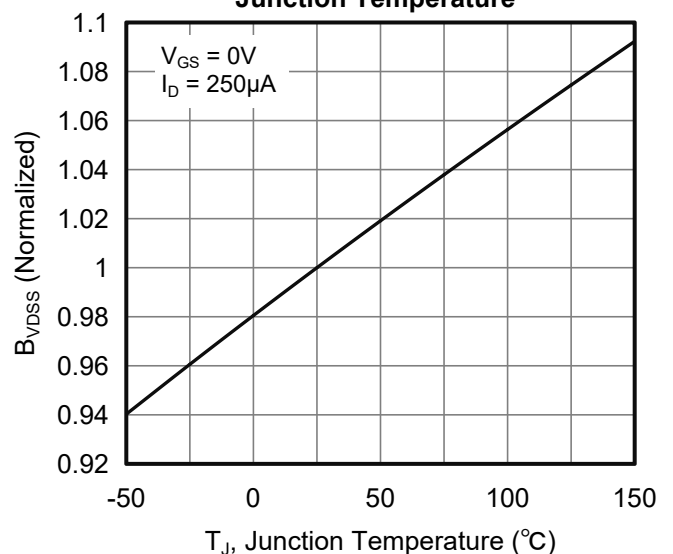

Figure 12. Normalized Breakdown Voltage vs Junction Temperature

Typical Characteristics $T_J = 25^\circ\text{C}$, unless otherwise noted

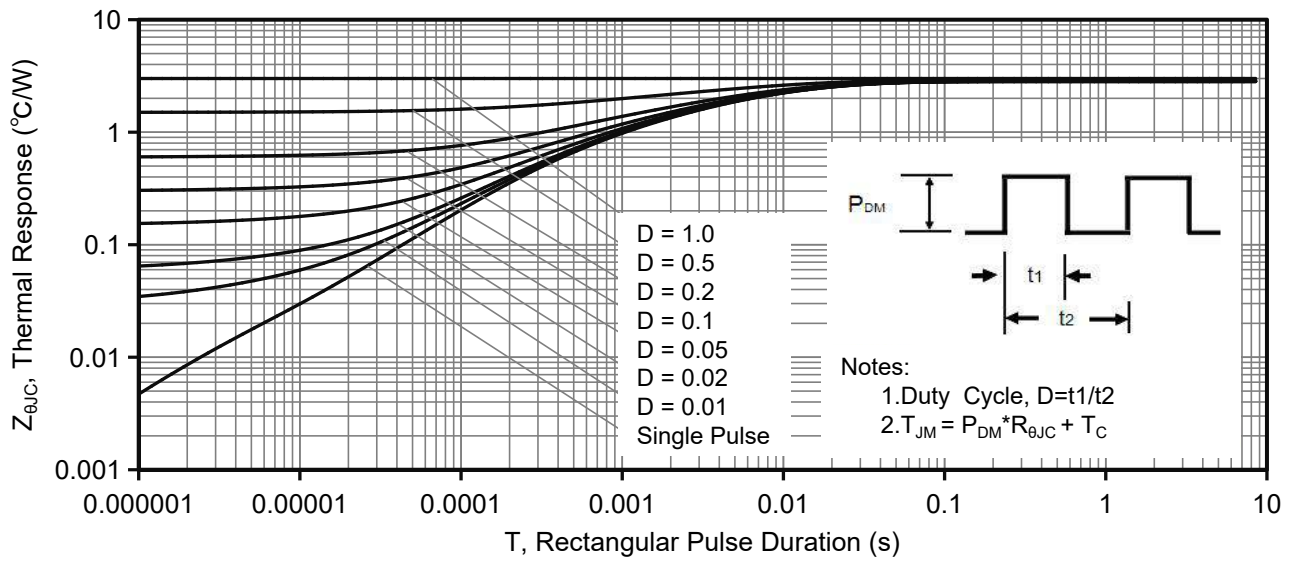

Figure 13. Maximum Effective Thermal Impedance, Junction to Case

Figure A: Gate Charge Test Circuit and Waveform

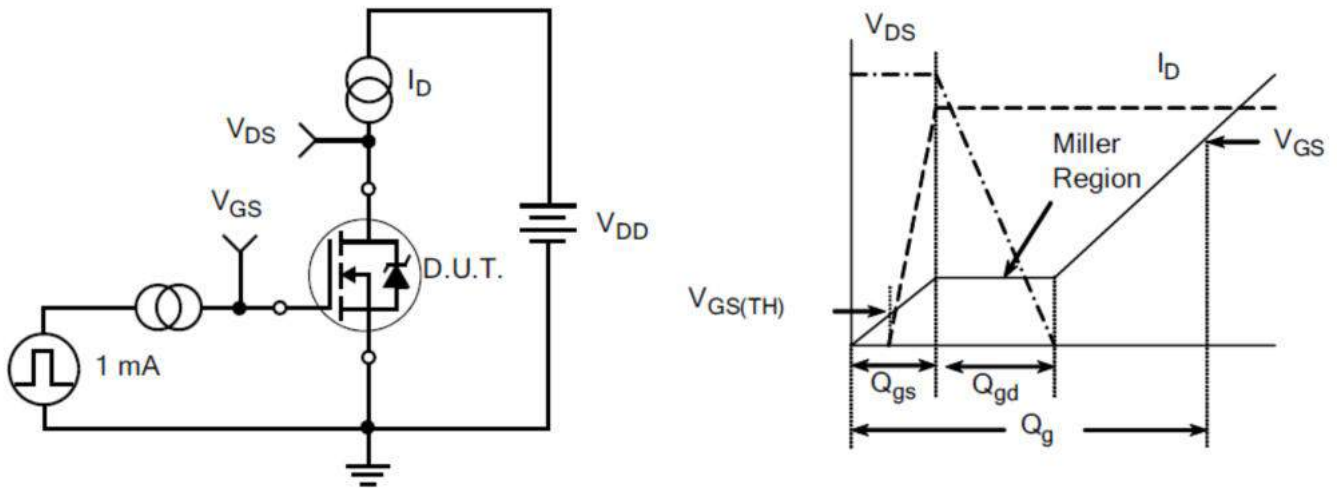

Figure B: Resistive Switching Test Circuit and Waveform

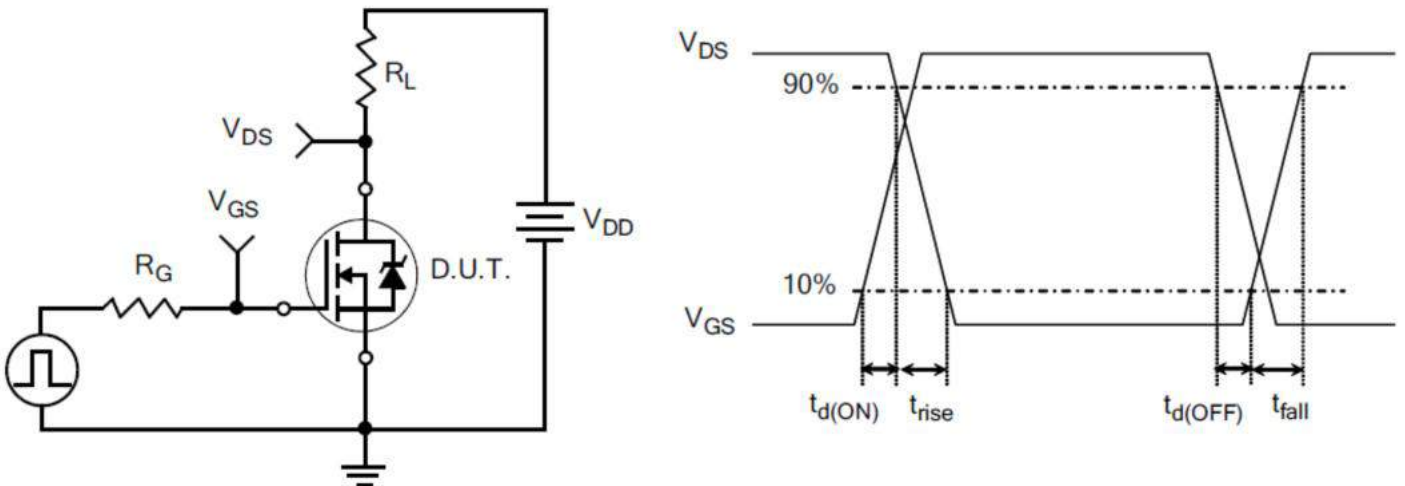
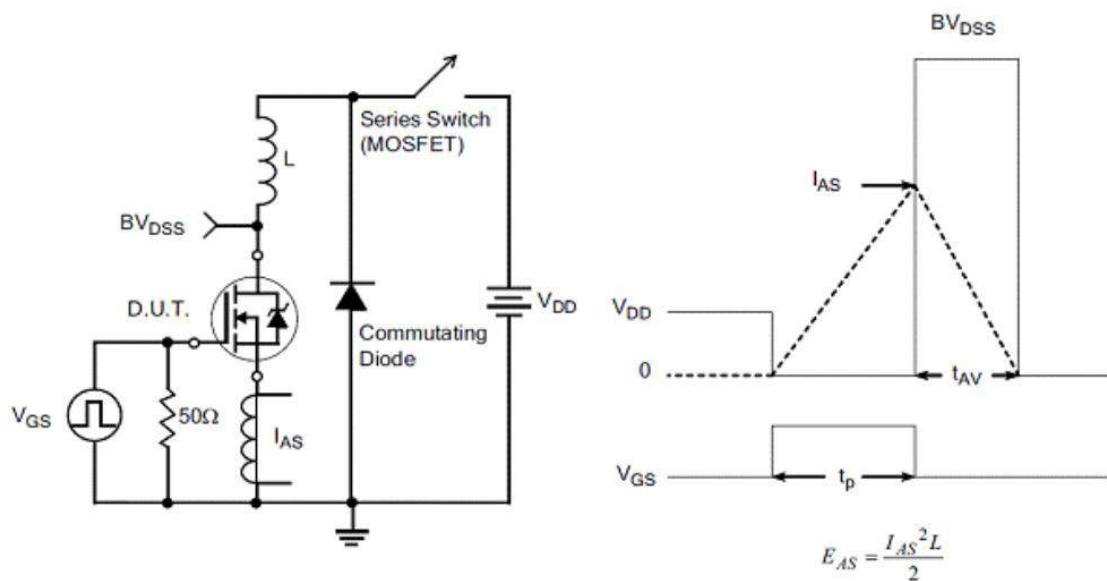
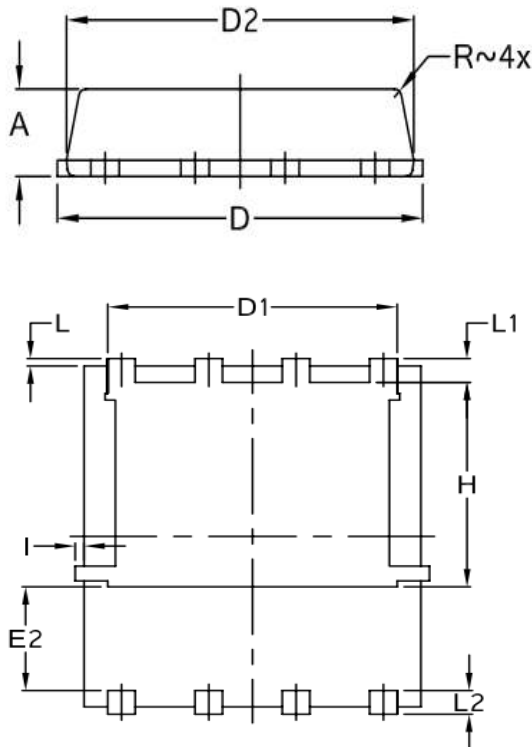
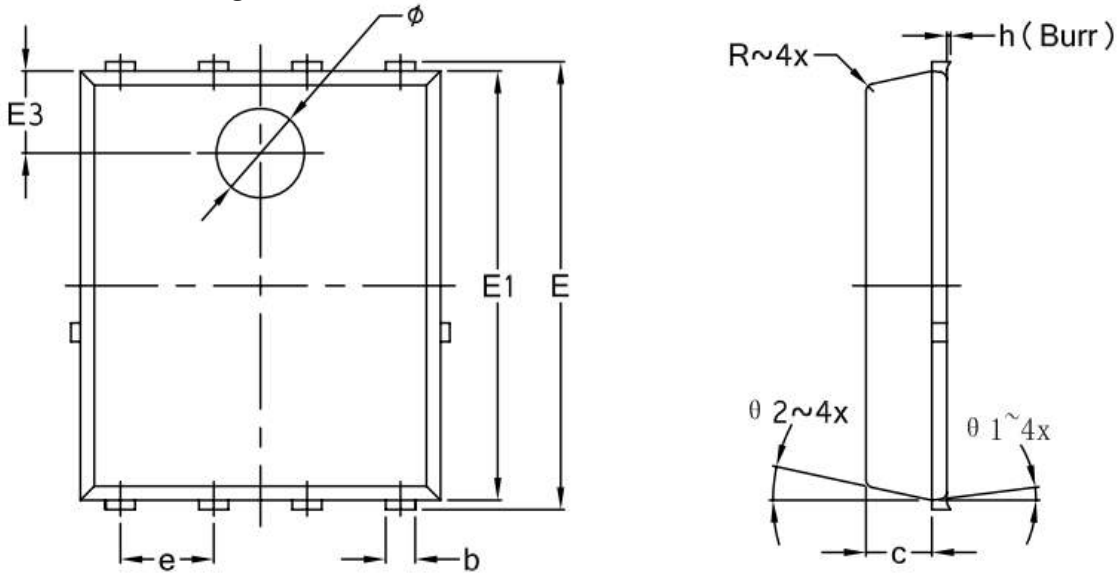

Figure C: Unclamped Inductive Switching Test Circuit and Waveform



DFN5x6-8L Package Information



SYMBOL	COMMON			
	MM		INCH	
	MIN.	MAX.	MIN.	MAX.
A	1.03	1.17	0.0406	0.0461
b	0.35	0.46	0.0138	0.0181
c	0.84	0.95	0.0331	0.0374
D	4.83	5.37	0.1902	0.2114
D1	4.14	4.28	0.1630	0.1685
D2	4.83	4.97	0.1902	0.1957
E	6.03	6.13	0.2374	0.2413
E1	5.68	5.82	0.2236	0.2291
E2	1.65	—	0.0650	—
E3	1.03	1.17	0.0406	0.0461
e	1.27 BSC		0.0500 BSC	
L	0.05	0.25	0.0020	0.0098
L1	0.40	0.48	0.0157	0.0189
L2	0.40	0.48	0.0157	0.0189
H	3.315	3.475	0.1305	0.1368
I	—	0.16	—	0.0063
phi	1.13	1.27	0.0445	0.0500
R	0.10		0.0039	
theta 1	7° REF		7° REF	
theta 2	12° REF		12° REF	
h	0.08 MAX		0.0031	

Customer Service

Sales and Service:

zj@ztasemi.com