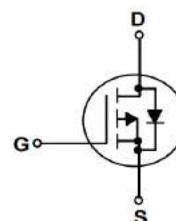
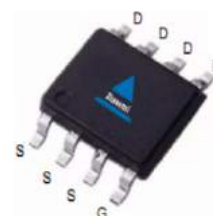

Features

- P-Channel
- Low Gate Charge
- 100% UIS Tested, 100% DVDS Tested
- High Power and current handing capability
- Lead free product is acquired
- 100% EAS Tested

V_{DS}	-30	V
$R_{DS(on),TYP@ V_{GS}=-10V}$	10	m Ω
$R_{DS(on),TYP@ V_{GS}=-4.5V}$	14.1	m Ω
I_D	-13.5	A

SOP-8

Part ID	Package Type	Marking	Packing
ZT4407	SOP-8	ZT4407	4000pcs/reel

Absolute Maximum Ratings $T_A = 25^\circ\text{C}$, unless otherwise specified

Symbol	Parameter	Rating	Unit	
Common Ratings ($T_C=25^\circ\text{C}$ Unless Otherwise Noted)				
V_{GS}	Gate-Source Voltage	± 20	V	
$V_{(BR)DSS}$	Drain-Source Breakdown Voltage	-30	V	
T_J	Maximum Junction Temperature	150	$^\circ\text{C}$	
T_{STG}	Storage Temperature Range	-55 to 150	$^\circ\text{C}$	
I_{DM}	Drain Current-Continuous@ Current-Pulsed (Note 1)	$T_C = 25^\circ\text{C}$ -54	A	
Mounted on Large Heat Sink				
I_D	Drain Current-Continuous	$T_C = 25^\circ\text{C}$	-13.5	A
		$T_C = 100^\circ\text{C}$	-8.5	A
P_D	Maximum Power Dissipation	$T_C = 25^\circ\text{C}$	3.6	W
		$T_C = 100^\circ\text{C}$	1.4	W
$R_{\theta JC}$	Thermal Resistance-Junction to Case	35	$^\circ\text{C/W}$	
Drain-Source Avalanche Ratings				
EAS	Avalanche Energy, Single Pulsed (Note 2)	100	mJ	

Electrical Characteristics (T_J=25°C unless otherwise noted)

Symbol	Parameter	Condition	Min	Typ	Max	Unit
Static Electrical Characteristics @ T_J=25°C (unless otherwise stated)						
V(BR)DSS	Drain-Source Breakdown Voltage	V _{GS} =0V, I _D =-250μA	-30	--	--	V
I _{DSS}	Zero Gate Voltage Drain Current	V _{DS} =-30V, V _{GS} =0V	--	--	1	μA
I _{GSS}	Gate-Body Leakage Current	V _{GS} =±20V, V _{DS} =0V	--	--	±100	nA
V _{GS(th)}	Gate Threshold Voltage	V _{DS} =V _{GS} , I _D =-250μA	-1.0	--	-2.5	V
R _{DS(on)}	Drain-Source On-State Resistance	V _{GS} =-10V, I _D =-6A	--	10	13	mΩ
R _{DS(on)}	Drain-Source On-State Resistance	V _{GS} =-4.5V, I _D =-4A	--	14.1	18	mΩ
g _{FS}	Forward Transconductance	V _{DS} =-5V, I _D =-6A	--	10	--	S
Dynamic Electrical Characteristics @ T_J = 25°C (unless otherwise stated)						
C _{iss}	Input Capacitance	V _{DS} =-15V, V _{GS} =0V, f=1MHz	--	1469	--	pF
C _{oss}	Output Capacitance		--	163	--	pF
C _{rss}	Reverse Transfer Capacitance		--	130	--	pF
R _g	Gate Resistance f=1MHz	f=1MHz	--	13	--	Ω
Q _g	Total Gate Charge	V _{DS} =-15V, I _D =-6A, V _{GS} =-10V	--	38	--	nC
Q _{gs}	Gate-Source Charge		--	8	--	nC
Q _{gd}	Gate-Drain Charge		--	9	--	nC
Switching Characteristics						
T _{d(on)}	Turn-on Delay Time	V _{DS} =-15V, R _L =2.5Ω, R _G =3Ω, V _{GS} =-10V	--	14.3	--	ns
T _r	Turn-on Rise Time		--	3	--	ns
T _{d(off)}	Turn-Off Delay Time		--	91	--	ns
T _f	Turn-Off Fall Time		--	35.4	--	ns
Source- Drain Diode Characteristics @ T_J = 25°C (unless otherwise stated)						
I _{SD}	Source-Drain Current (Body Diode)		--	--	-13.5	A
V _{SD}	Forward on voltage ^(Note 3)	I _S =-6A, V _{GS} =0V	--	--	1.2	V
T _{rr}	Reverse Recovery Time	T _J =25°C, I _{SD} =-3A, V _{GS} =0V	--	14.2	--	ns
Q _{rr}	Reverse Recovery Charge	di/dt=100A/μs	--	5	--	nC

Notes :

- 1.Repetitive Rating: Pulse width limited by maximum junction temperature.
- 2.E_{AS} condition: T_J=25°C, V_{DD}=-30V, V_G=-10V, R_g=25Ω, L=0.5mH.
- 3.Repetitive Rating: Pulse width limited by maximum junction temperature.

Typical Electrical And Thermal Characteristics (Curves)

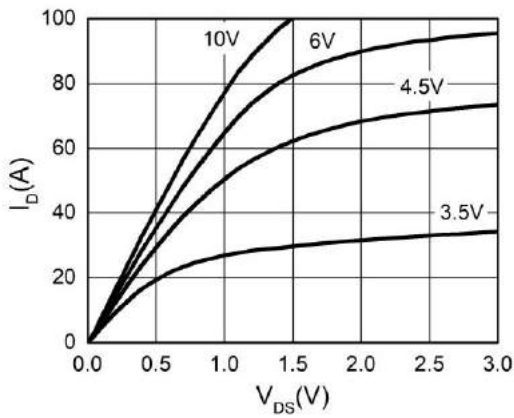

Figure 1. Output Characteristics

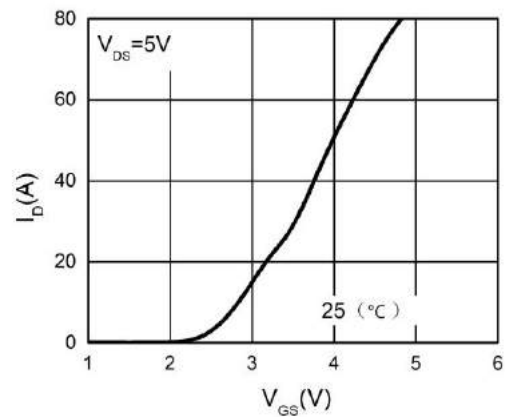

Figure 2. Transfer Characteristics

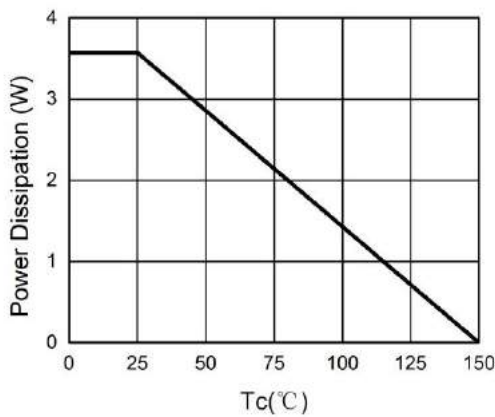

Figure 3. Power Dissipation

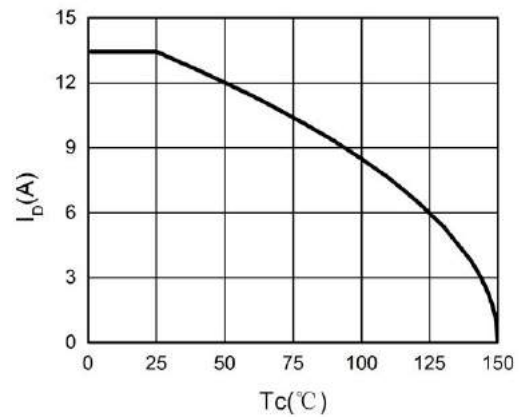

Figure 4. Drain Current

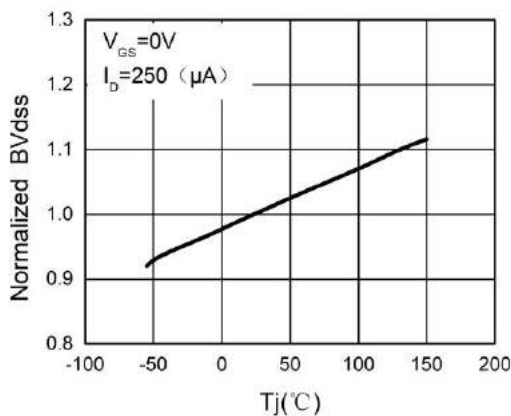

Figure 5. BV_{DS} vs Junction Temperature

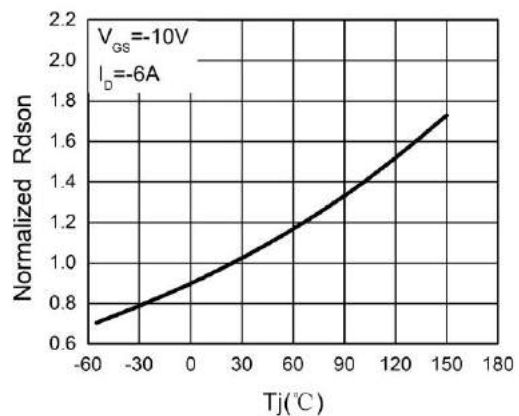

Figure 6. $R_{DS(on)}$ vs Junction Temperature

Typical Electrical And Thermal Characteristics (Curves)

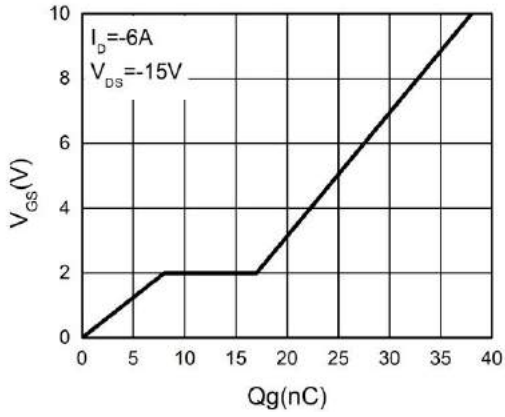

Figure 7. Gate Charge Waveforms

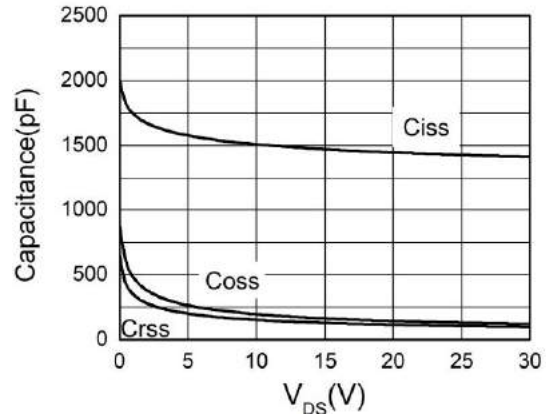

Figure 8. Capacitance

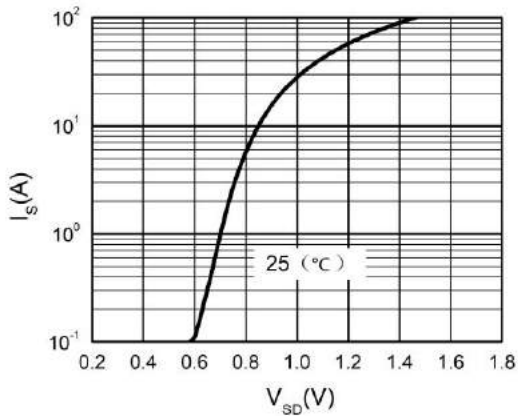

Figure 9. Body-Diode Characteristics

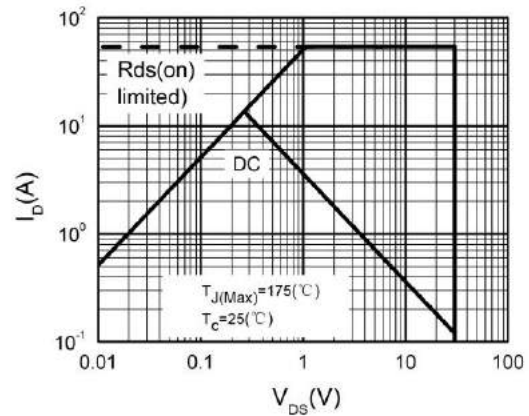
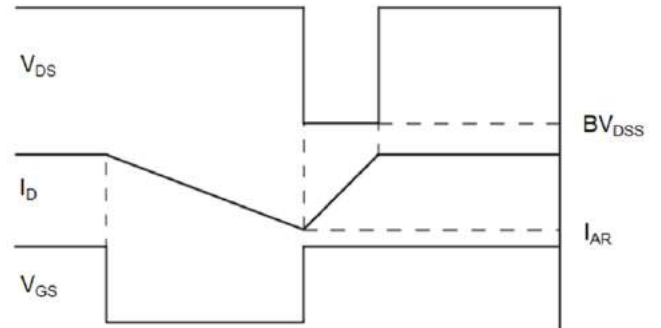
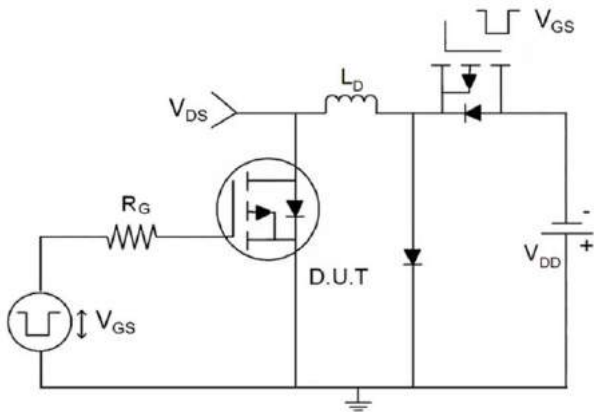

Figure 10. Maximum Safe Operating Area

Test Circuit

1) E_{AS} Test Circuits



2) Gate Charge Test Circuit

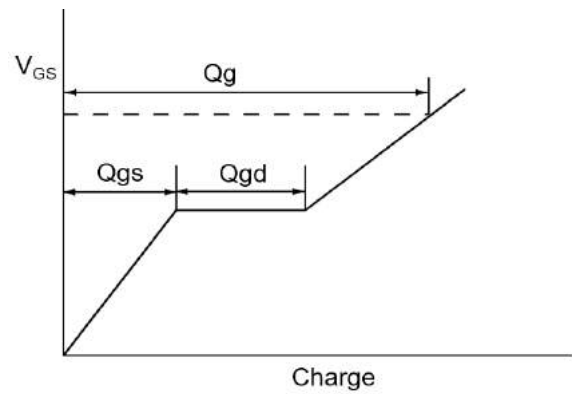
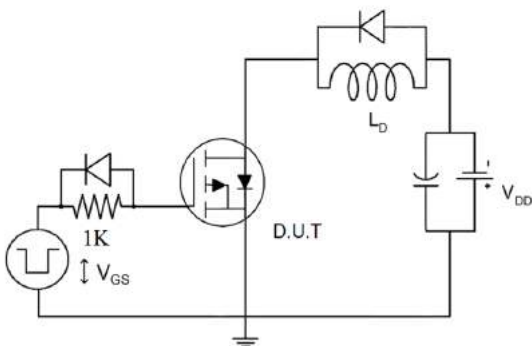

3) Switch Time Test Circuit

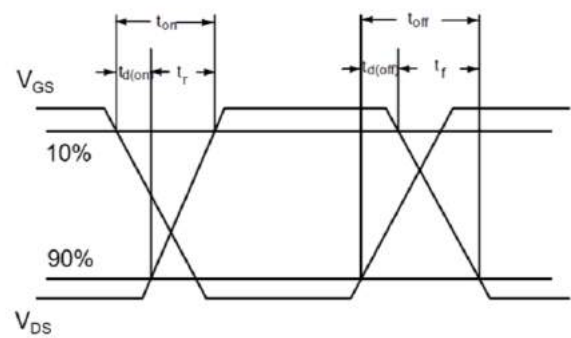
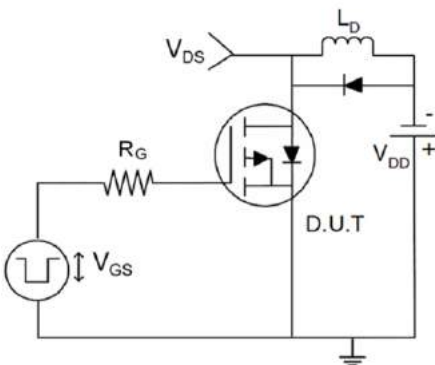

SOP-8 Package Information

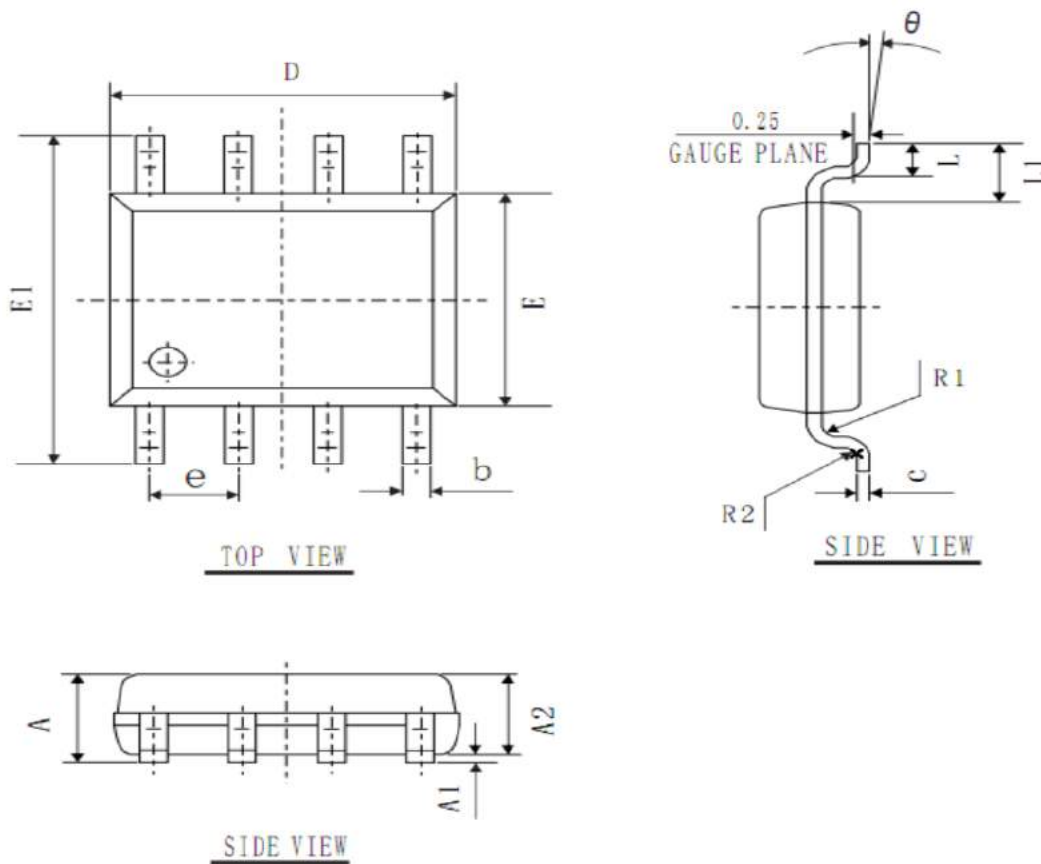

COMMON DIMENSIONS
(UNITS OF MEASURE=mm)

SYMBOL	MIN	NOM	MAX
A	1.40	1.60	1.80
A1	0.05	0.15	0.25
A2	1.35	1.45	1.55
b	0.30	0.40	0.50
c	0.153	0.203	0.253
D	4.80	4.90	5.00
E	3.80	3.90	4.00
E1	5.80	6.00	6.20
L	0.45	0.70	1.00
θ	2°	4°	6°
L1	1.04 REF		
e	1.27 BSC		
R1	0.07 TYP		
R2	0.07 TYP		

Customer Service

Sales and Service:

zj@ztasemi.com